

Model(s): SRC, SRV, SRTA

Overview:

Safety Railing products are designed for use as a safety accessory to roof hatch, smoke vent and floor door products. The following are general instructions for installing, operating and maintaining safety railing products. These are recommended general guidelines only.

Tools Required:

- Level
- Marking Tool
- Drill
- 1/2 inch drill bit
- Caulking
- 3/16 inch allen wrench (included)
- 1/2 inch wrench
- 9/16 inch socket
- Torque wrench

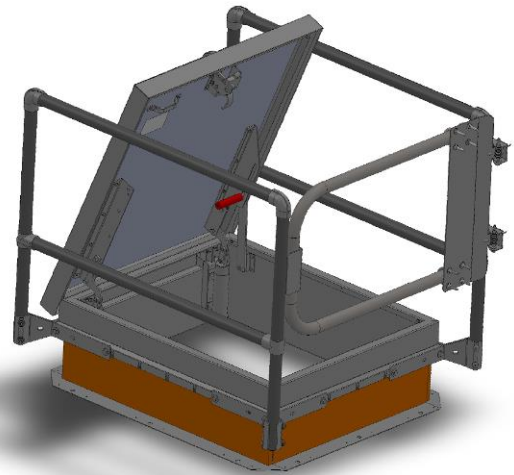

Unpack and Set Up:

Railings may ship in multiple boxes, depending on its size and exit configuration. To help keep systems together, the boxes will come banded together that form a full system.

Installation:

Reference *Figure 1* for installation of Post Brackets, Corner Posts, Center Posts, Top Rails, Middle Rails and Self Closing Gate.

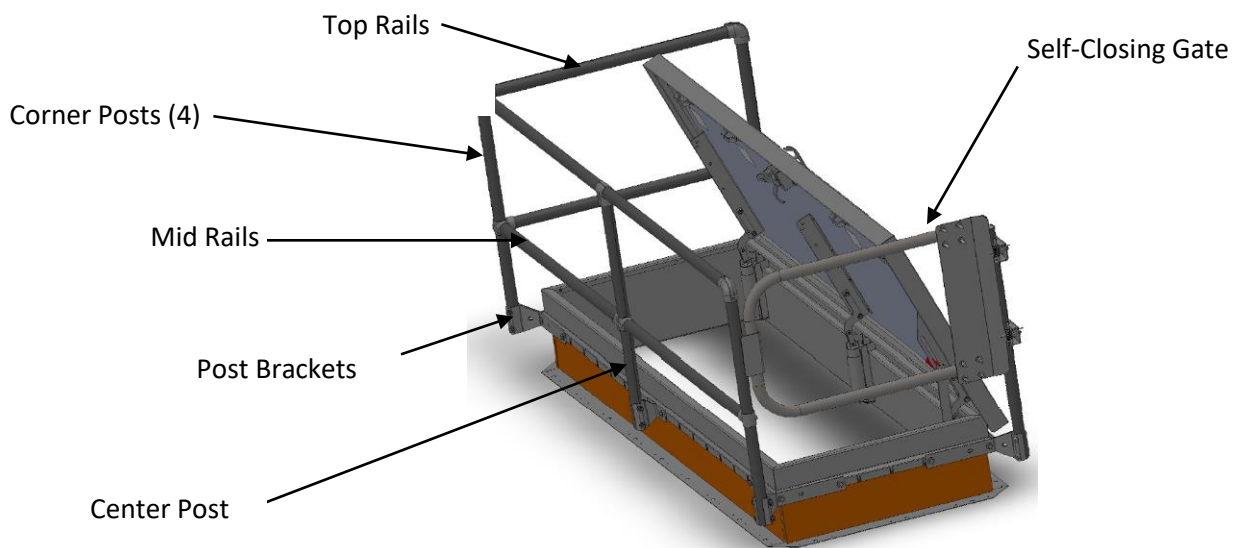

Figure 1

Corner Posts and Post Brackets: (See Figure 2) Note the position of the door in open position.

- Temporarily assemble **corner brackets** using temporary assembly holes in bracket halves (10) and a 3/8-16 nut and bolt (20, 30) See Figure 2.

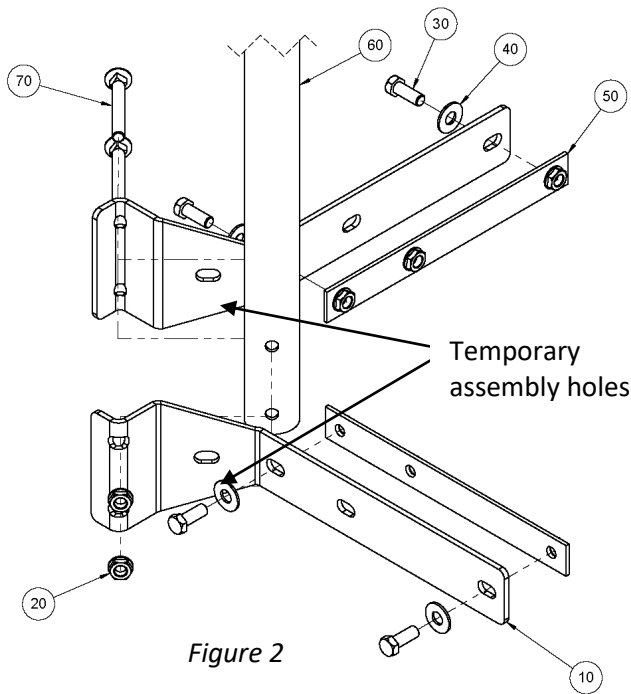

Figure 2

ITEM NO.	DESCRIPTION	QTY
10	CORNER BRACKET, HALF, 1-1/4 inch PIPE	2
20	NUT, HEX, LOCK, FLANGE, 3/8-16	2
30	HEX HEAD SCREW, 3/8-16 x 3/4 inch	4
40	WASHER, FLAT, 3/8	4
50	THREADED NUT PLATE	2
60	POST, GALV or ALUM , 1/1/4 inch, SCHEDULE 40	1
70	CARRIAGE BOLT, 3/8-16 x 3.00	2

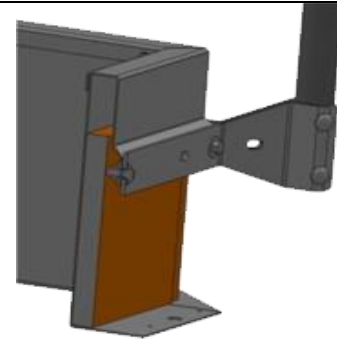

Figure 3

- The railing brackets are designed for mounting on the counterflash of the roof hatch. See Figure 3. **Do not mount brackets through the roof hatch curb or through roofing material.**
- Ensure that the bracket is sitting square and level on the counterflash.
- Mark the mounting holes on each corner and drill 1/2 inch diameter holes. Remove 3/8-16 nut and bolt (20, 30) from bracket halves (10).
- Fasten to the corner on counter flashing using 3/8-16 x 3/4 inch bolts (30), washers (40) and threaded nut plate (50), which is placed behind the counterflash for quick, easy installation.
 - If mounting holes were drilled, apply roofers' caulk around hole in counter flashing.
 - Align and hold the threaded nut plate (50) behind the counter flash.
 - Screw the 3/8-16 x 3/4 inch bolts (30) and washers (40) through the bracket and into the threaded nut plate.
- Tighten all mounting brackets to the counter flashing making sure that all brackets are square and level with each other.
- Set torque to 29ft/lbs.
- Insert the 35 inch upright post (60) into the installed brackets and insert the 3/8-16 x 3 inch bolts (70). Tighten the bolts using the 3/8-16 nuts (20).
- Repeat for all corner posts.

Center Post: (See Figure 1) Note the position of the door in open position. Center posts are included for roof hatch lengths > 8 feet.

- Temporarily assemble **center brackets** using temporary assembly holes in bracket halves and a 3/8-16 nut and bolt. (See Figure 2 for example with corner brackets)
- Assemble top rail and center post. Temporarily attach it to corner posts to verify location of center post bracket.
- Assure that the bracket is sitting square and level on the counter flashing.
- Mark the mounting holes on the counter flash and drill 1/2 inch diameter holes. Remove 3/8-16 nut and bolt from bracket halves and top rail assembly.
- Fasten to the center of the counter flashing using 3/8-16 x 3/4 inch bolts, washers, and threaded nut plate.
 - If mounting holes were drilled, apply roofers' caulk around hole in counter flashing.
 - Align and hold the threaded nut plate behind the counter flash.
 - Screw the 3/8-16 x 3/4 inch bolts and washers through the bracket and into the threaded nut plate.
- Tighten all mounting brackets to the counter flashing making sure that all brackets are square and level with each other.
- Set torque to 29ft/lbs.
- Insert the 35 inch upright post into the installed brackets and insert the 3/8-16 x 3 inch bolts. Tighten the bolts using the 3/8-16 nuts.
- Repeat for all center posts.

Railing Top and Middle Rails: (See Figure 1) Note the position of the door in open position.

- If necessary, cut horizontal rails to appropriate length.
- Assemble the appropriate fittings with the horizontal rails and tighten the set screws using the provided 3/16 inch allen wrench.
- Slide the horizontal mid rails over the upright posts.
- If necessary, install collar fitting over upright post that will not have an elbow.
- Install the top rails over the upright posts and tighten the set screws.
- Position the mid rail 21 inch, center to center, from the top rail.
- If necessary, install end cap on single upright post.

Exit Option- Self Closing Gate

- Railing packages include a chain. If installing a gate, the chain is not used.
- Remove provided hardware pouch attached to the safety gate.
- Install safety gate using two U bolt mounting brackets on applicable upright post.
- Set the safety gate to the height of the top safety rail and temporarily tighten using the provided hardware.
- Rotate gate hinges so the gate stop makes contact with the opposing upright post.
- Tighten U-Bolt on the hinge to 20 ft/lbs.
- Test the full range of gate operation to ensure the gate automatically closes when opened fully.

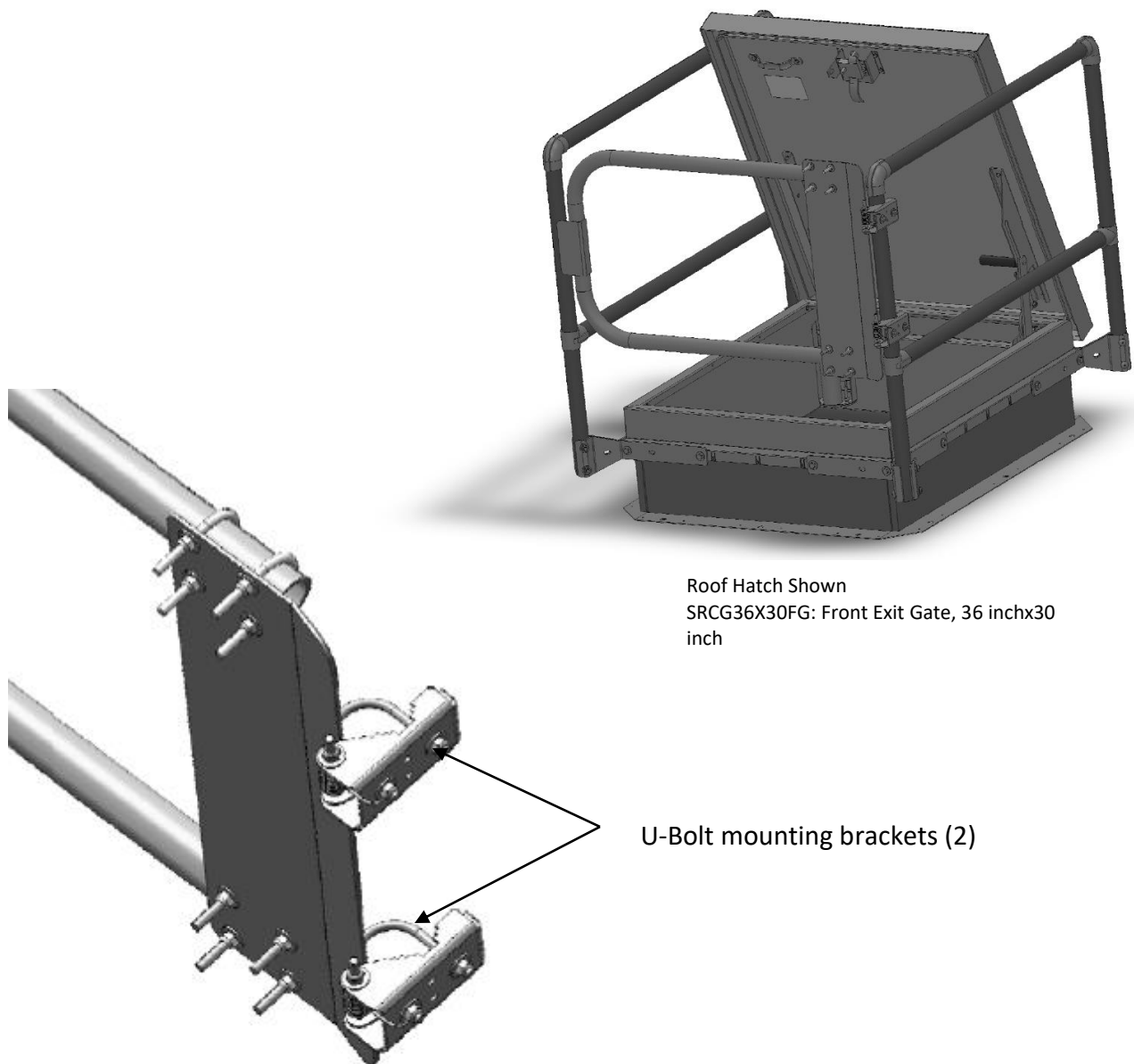

Roof Hatch Shown
SRCG36X30FG: Front Exit Gate, 36 inchx30
inch

U-Bolt mounting brackets (2)

Exit Options – Chain

- This option is intended for roof hatches and floor door applications.
- Remove set screws from top elbow or collar fitting of railing system.
- Install provided eye bolts in set screw holes.
- Assemble chain and spring clips and install on eye bolts.

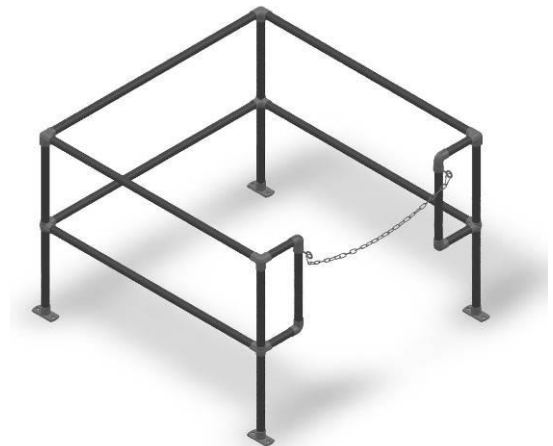
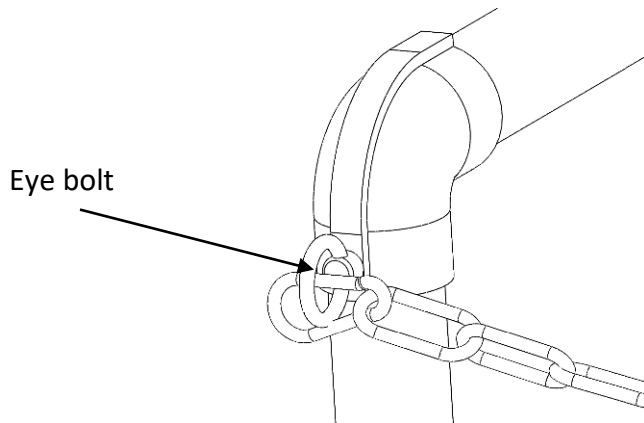

Floor Door Railing Shown
SRTA36X36FC: Front Exit Chain, 36 inchx36 inch

Exit Options- No Exit, all sides with rails

- This option is intended for smoke vents as well as equipment roof hatches, when there is no required exit.



Smoke Vent Shown
SRVA48X96NN: No Exit, 48 inchx96 inch

Operation

Assure that all the fasteners are fastened to the suggested torque. The gate should fully open and close with no interference. The roof hatch should operate without interfering with the safety railing.

Maintenance

It is recommended that the springs in gate be lubricated once a year to preserve the spring, and that all fasteners meet the recommended torque setting.

If any questions arise during the operation or maintenance of the products, please feel free to call our toll-free number for assistance, 1-888-412-3726.