



ASSEMBLY INSTRUCTIONS

SAFEPRO AUTOMATIC ROOF HATCH OPENER

REQUIRED TOOLS

- Drill
- Drill bits: 1/4" & 9/64"
- Wrench Set 1/2" & 9/16"
- Socket set

RECOMMENDED TOOLS

- Automatic center punch
- Hammer
- Marker
- Tape measure

ASSEMBLY VIDEO:

Scan the QR code below with your smart device to watch an instructional video.

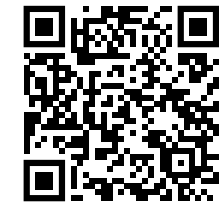

For more fall protection products and tutorials, visit safeprosafety.com

INCLUDED PARTS (HARDWARE)



INCLUDED ELECTRONIC PARTS



INSTALLATION

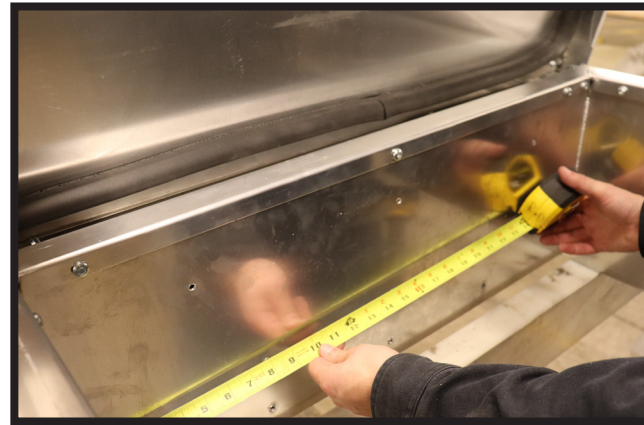

- 1.** Line up the center of the back bracket with the center of the hatch.



- 2.** Line up the bottom of the back bracket even with the bottom of the hatch curb, then mark the center of the slotted holes.



- 3.** Drill where you marked with the 1/4" drill bit.



- 4.** Mount the back bracket with the ears flat side up using the 5/16-18 body bolts. Let the bolts thread themselves. Make sure the bolts are snug but be careful not to over tighten them especially with an aluminum hatch. Note: This is for a hatch with a 12" curb. If you have a 12" curb you can mark and drill all 6 holes. If your curb is different don't drill the two holes in the middle, wait until the end when everything is adjusted before adding them.

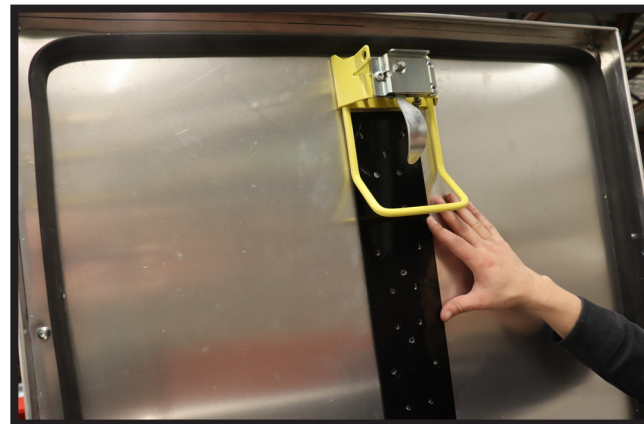

- 5.** With the lid open, find the center point of the latch, then mark a short vertical line immediately below on the latch. If there is a fixed grab handle below the hatch, remove it, as it's unnecessary and will be in the way.



- 6.** Line up your door plate with the center mark under the latch. Mark the 8 outer holes then drill with the 1/4" drill bit. Note: It may be helpful to only drill one of the top corners and mount the door plate with one body bolt then use the door plate as a guide to drill a hole and install another body bolt one at a time all the way down.

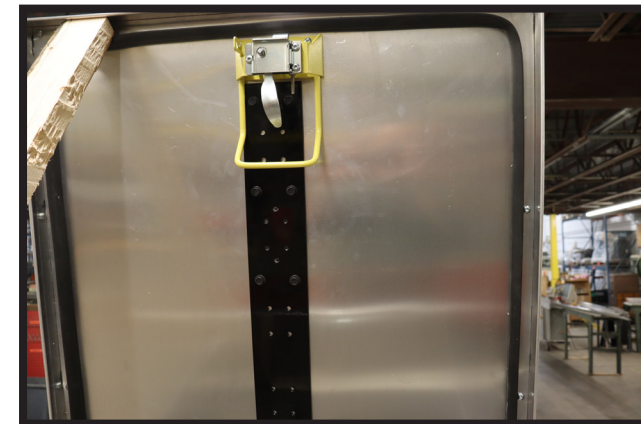

- 7.** Fasten the door plate using the 5/16" body bolts.

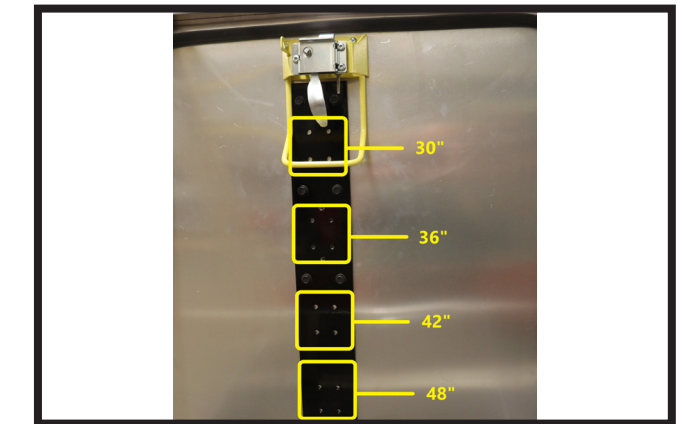

- 8.** Now drill the four inner holes corresponding with your hatch size. This measurement will be from the hinge side to the latch side, inside dimension.

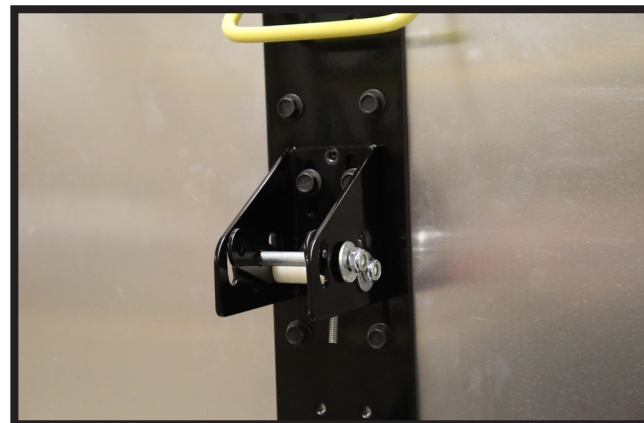

- 9.** Mount the rocker bracket with the flat side down using the 5/18 body bolt, keeping the bolts loose enough to slide the rocker bracket up and down. This will help with the adjustment later.

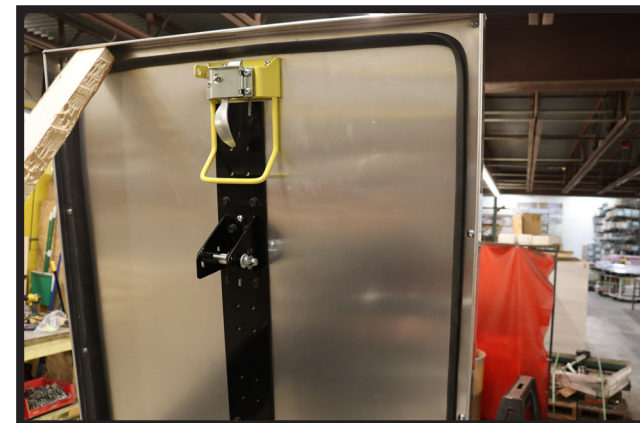

- 10.** It should now look something like this.



- 11.** Remove the latch assembly
Your latch may look different. See "Alternative Latch Types" for instructions if this is the case.

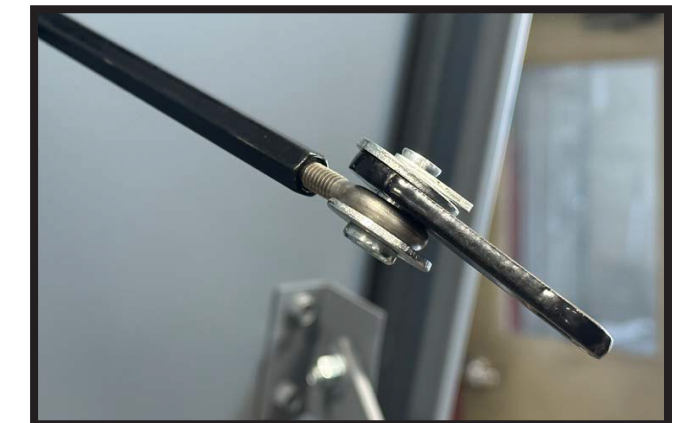

- 12.** Assemble the latch bracket with the turnbuckle using the clevis pin. Note: you may need to add extra washers to take out some slop.

INSTALLATION (CONT.)

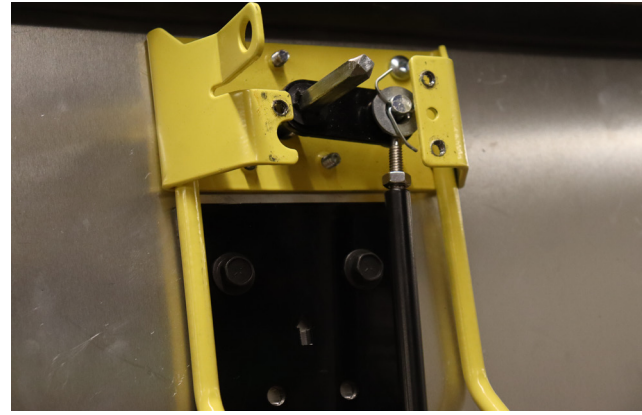

- 13** Slide the Latch Bracket over the latch rod as pictured, then secure it with the Push-on Lock Washer. (Note: Be sure not to push it on too far as the bracket may rub.)

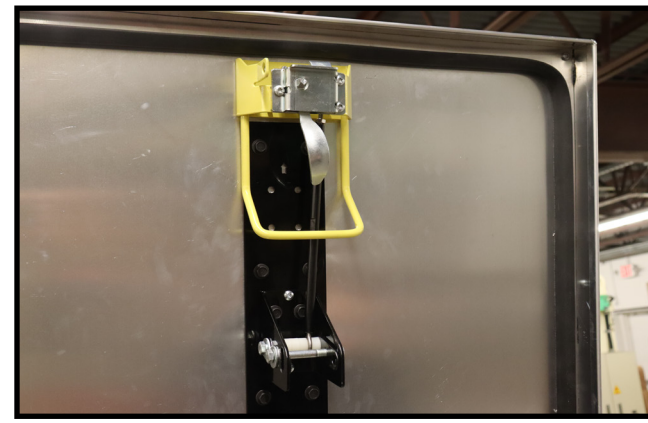

- 14** Re-install the latch assembly

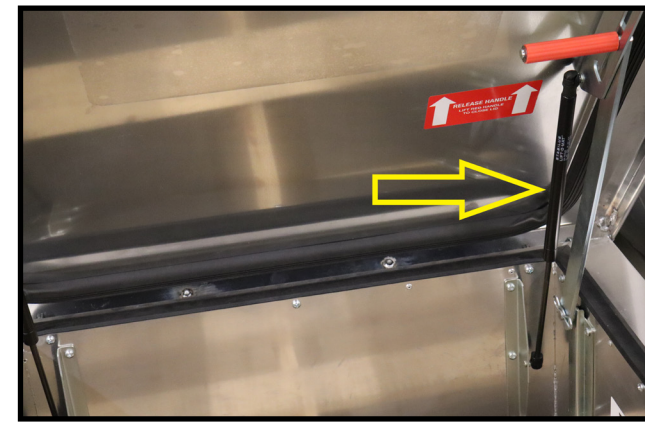

- 15** Remove the springs / gas strut. **Springs are under extreme pressure! Use CAUTION when removing!** (Note: Larger hatches may have more than two springs. If that is the case it is recommended to remove just enough springs to not have the lid pop up when the latch is open but still be able to lift it by hand. This will make adjusting the latch much easier later.)



- 16** Install the DIN Rail centered above the back bracket, drill 3 pilot holes using a 9/64" bit then attach the DIN Rail using the 1/4" body bolts

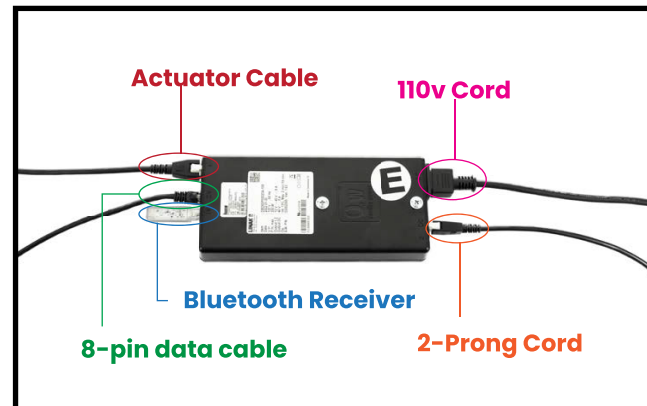

- 17** Plug in all the cables to the controller box.
1. Port 1: Actuator Cable
 2. Port A1: 8-pin data cable
 3. Port A2: Bluetooth Receiver
 4. AC Port: 110v cord
 5. DC: 2-prong cord

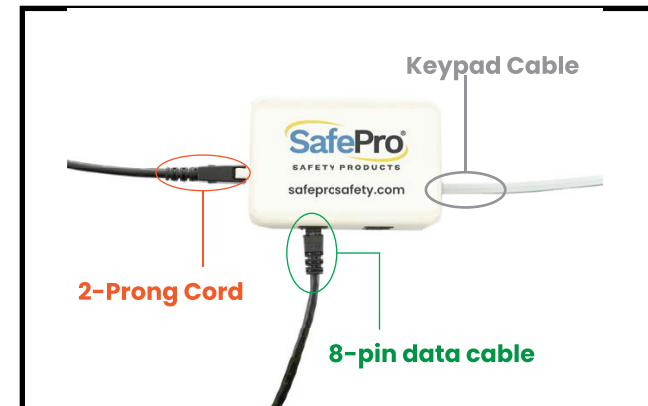

- 18** Plug in all the cables to the signal box.
1. DC: 2-prong cord
 2. Bottom: 8-pin data cable
 3. 6-pin connector: Keypad cable



- 19** Now mount the controller and the signal box to the DIN rail from Step 16. You should be able to push and click them into place.



- 20** Install the bottom of the actuator into the Back Bracket (from step 4) using a 3 inch bolt and a flat washer, with 2 nylon spacers on either side of the actuator mount on the inside. Finish with a flat washer and nut on the other end and tighten.



- 21** Plug the actuator into the actuator cable then plug the AC cord into an outlet to power the ARHO.



- 22** Pair the remote with the receiver. To do so, wait until the LED on the receiver begins to flash (approx. 10 seconds), then press and hold both the up and down arrow button on the remote simultaneously until the blue LED goes solid. You are now paired.

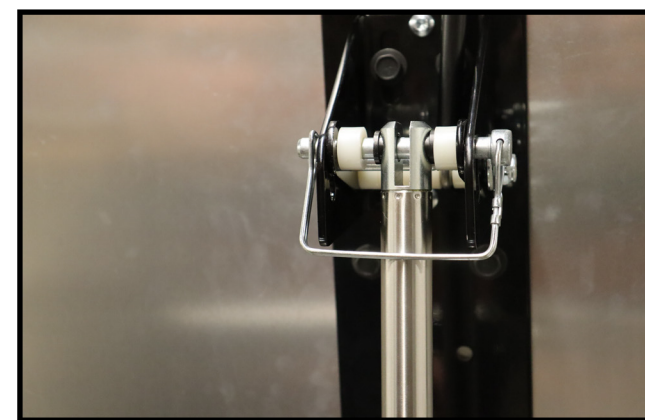

- 23** Now, using the remote, extend the actuator all the way out and connect it to The Rocker Bracket (from step 9) with the 3" locking pin and two Nylon Spacers on either side of the shaft as pictured. (Note: You may need to go down with the actuator to reset it before it will start going up.)

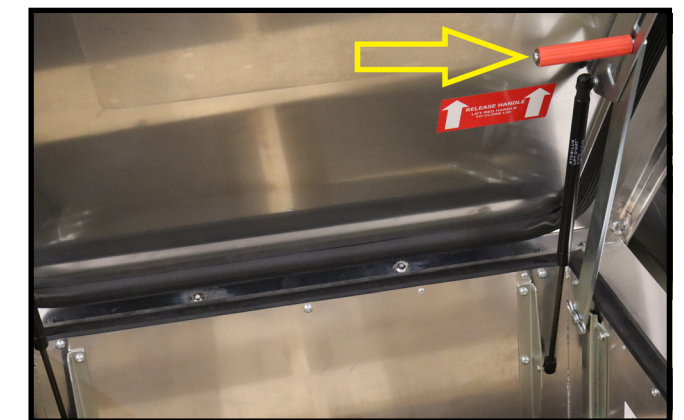

- 24** **IMPORTANT! Do not skip step before doing anything else!**
Once the actuator is installed, the first thing you must do is remove the kickstand. Damage will occur to the hatch itself and the ARHO if not done.

ADJUSTMENTS

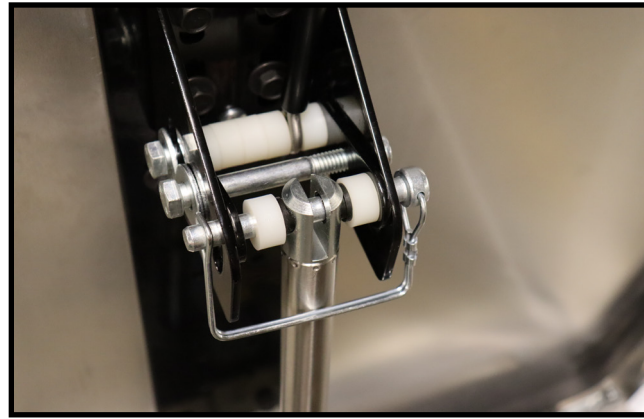

- 25** Close the hatch all the way and watch the rocker bracket, you should see it move forward or backward. This is normal. With the hatch closed and the actuator all the way in, tighten the four bolts on rocker bracket.

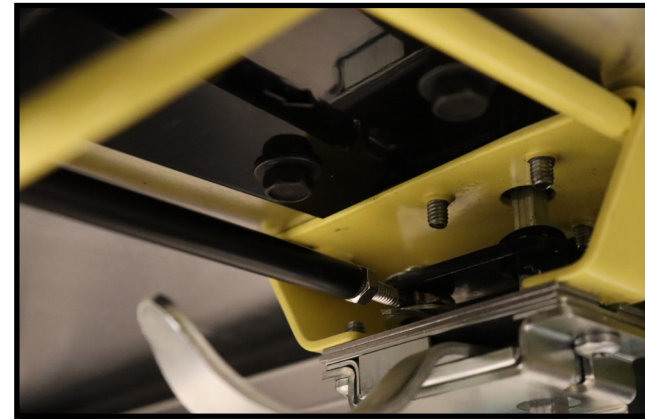

- 26** Adjust the latch by twisting the turnbuckle to ensure that the latch clears the striker when the lid starts to open.
IMPORTANT! Watch the latch when moving the lid up for the first time to make sure the latch clears the striker. If it doesn't clear and you continue to go up with the lid it will cause damage! If the latch doesn't clear the striker, STOP IMMEDIATELY and adjust the turnbuckle to bring the latch in farther.

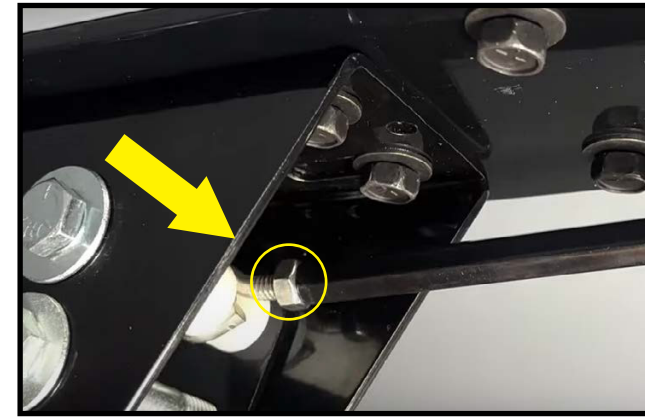

- 27** Once the turn buckle is adjusted properly, use two wrenches and tighten the jam nut against the turn buckle so that the latch doesn't loosen over time and cause damage in the future.

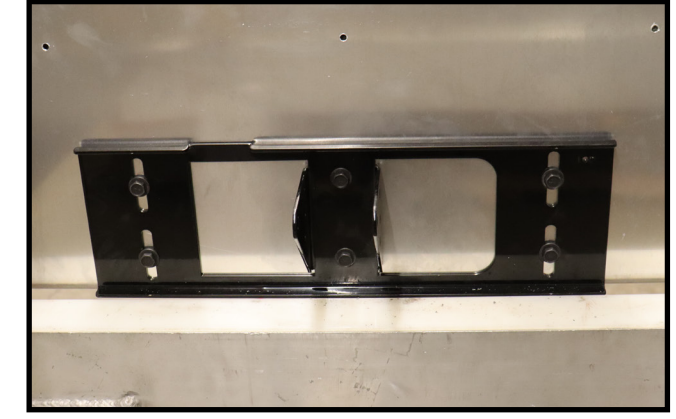

- 28** If the lid doesn't close enough or closes too much (closes before the actuator is fully retracted) you will need to adjust the back bracket (step 4). Loosen the four outer bolts on the back bracket. Moving the back bracket UP will make the lid close less. Moving the back bracket DOWN will make it close more. (Note: It is recommended to only move the back bracket 1/2" at a time to avoid over correcting and possibly causing damage). Once finished replace the center bolts, drilling new holes if necessary.

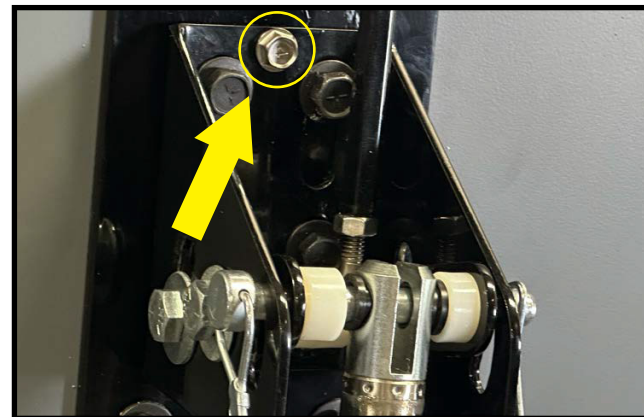

- 29** Once everything has been adjusted and is functioning properly use the self-tapping screw to lock in the rocker bracket as pictured above

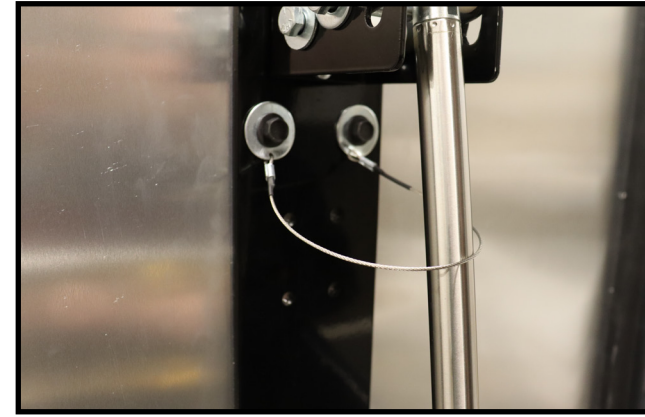

- 30** Underneath the rocker bracket, remove the two body bolts and install the safety cable, ensuring that it is installed around the actuator to prevent it from falling in the event that you need to disconnect it.

KEYPAD USE



Install the Keypad wherever you want. (Recommended at the bottom of the ladder), and plug in the other end of the keypad cable. To operate the ARHO with the Keypad enter the user code, then # (factory default is **0000#**) Press and HOLD the UP/DOWN button.

TO REPROGRAM THE KEYPAD

Master Code

1. Wait 1 minute after the Keypad is powered up to stop beeping.
2. Set Keypad into programming mode with the factory programming code **1234**** you should hear two beeps; it is now ready to program. (Note: The master code is for setting user codes or adding RFID cards, the master code does NOT operate the hatch)
3. Change the factory master code to owner's master code (master code cannot be the same as a user code). **INPUT 01 - (New Master Code) - #** You will hear two beeps to confirm entry.
4. Press ****** to exit programming.
5. Example: **01 - 4321 - # - ****

RFID Card

1. First **INPUT (Owner's Master Code) - ****. Pressing **20** prepares the system for a new authentication method. Next, pressing **1** will allow for an RFID card, or pressing **2** will prepare it for a new user code. Next, enter a User ID, from **001** to **100**. This must be unique for each user code or RFID card used.
 2. Scan the RFID card, then press **#**. You can add another card by pressing **20** again and going through the steps with a different User ID.
 3. Press ****** to exit programming.
- Example: [For User ID #1 **INPUT 20 - 1 - 001 - Scan Card - #**] [For User ID #2 **INPUT 20 - 1 - 002 - Scan Card - # - ****]

User Code

1. First **INPUT (Owner's Master Code) - ****
 2. Press **20** to prepare the system, then press **2** to choose user code as the method, then enter a unique User ID from **001** to **100**. Then input the new user code and press **#**. You will hear two beeps to confirm entry.
 3. Press ****** to exit programming.
- Example: [For User ID #3 **INPUT 20 - 2 - 003 - 3333 - #**] [For User ID #4 **INPUT 20 - 2 - 004 - 4444 - # - ****]

Delete a User Code or Card

1. First **INPUT (Owner's Master Code) - ****
2. Press **20 - 5 - (User ID or Scan Card) - #**
3. Press ****** to exit programming.

ALTERNATIVE HATCH TYPES



1 Some hatches are not flat across the back wall. With hatches like this, you must install an Extender Kit (not provided. Must contact SafePro). The extender consists of (2) 4-hole plates, (4) 3/8-16 x 1/2" round head slotted bolts, and (4) 3/8-16 nuts.



2 Following the same angle as the ears of the back above, you should have one hole protruding from the end of the back bracket ears. Follow the same steps as in steps 1-4 but with the ears of the back bracket side down. Now move back to Step 5 and continue



3 Follow the same steps as the back bracket installation but with the ears of the back bracket flat side down. Now move back to step 8 and continue.

ALTERNATE LATCH TYPES

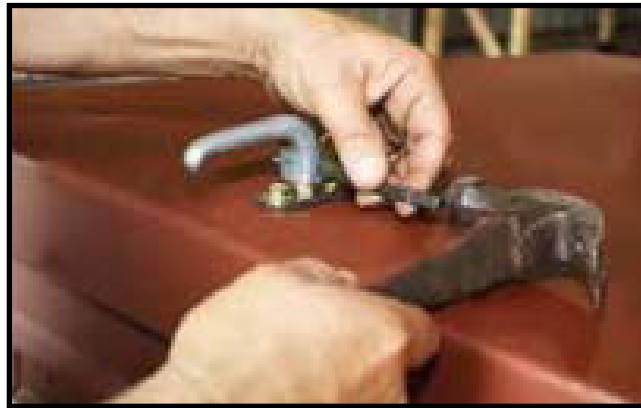

1 Different roof hatch manufacturers use different latches. While removing the handle, make sure the hatch lid is open. Using your 1/8" punch and hammer, knock out the retaining pin located at the base of the handle shaft.

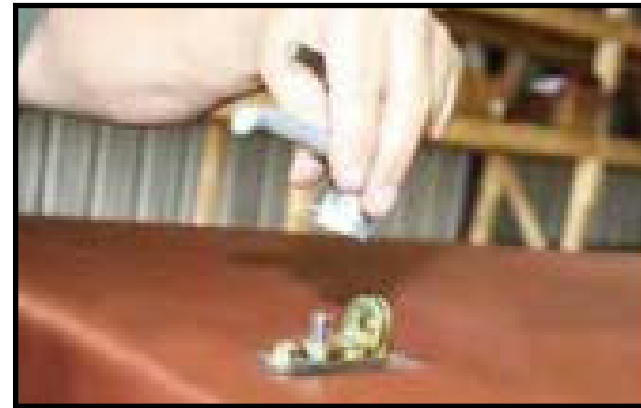

2 Once the pin has been removed you can pull the handle off of the hatch.



3 Continue to remove the entire latch assembly.



4 You can use an angle grinder to remove the bottom wall. If you do not have an angle grinder, you can use pliers to bend the wall up and down until it breaks off. This works just fine.

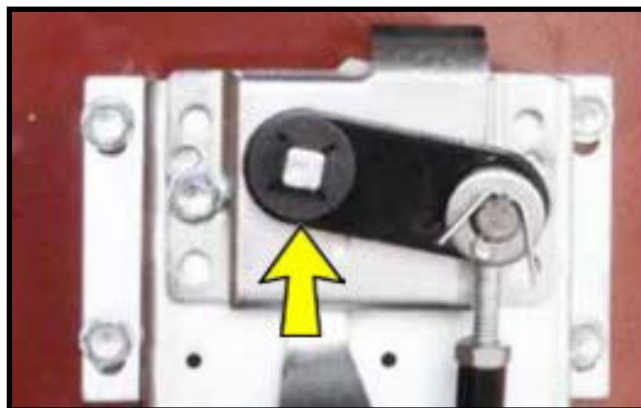

5 With this latch type, there is no need to remove the latch assembly. The handle rod protrudes from the assemble allowing you to use the included Latch Rod Lock Nut. Once your Turnbuckle Assembly is ready, slide the square hole of the Latch Bracket over the protruding rod. Press the Latch Rod Lock Nut onto the protruding rod. This will lock the Turnbuckle assembly in place. Once this is complete, you can move on.



6 If you have a two-actuator system or don't want to use the latch you can take all the hardware off the Rocker Bracket then add the actuator to the center hole using the 3" locking pin and some nylon spacers, you will then need to disable the latching mechanism.

BACKUP BATTERY (OPTIONAL)



Mount the backup battery on the right side of the DIN rail next to the signal box and plug it into the signal box using the DC plug.

EXTERIOR KEYPAD (OPTIONAL)



- 1 Mount the exterior Keypad to the rail using the provided Tek screws as pictured and run the cable into the hatch by the hinge

EXTERIOR KEYPAD PROGRAMMING

Install the Keypad wherever you want.

Master Code Programming

1. Wait 1 minute after the exterior keypad is powered up to stop beeping.
2. Set Keypad into programming mode with the factory programming code **1234**** you should hear two beeps; it is now ready to program. *(Note: The master code is for setting user codes or adding RFID cards, the master code does NOT operate the hatch)*
3. Change the factory master code to owner's master code (master code cannot be the same as a user code). **INPUT 01 - (New Master Code) - #**
You will hear two beeps to confirm entry.
4. Press ****** to exit programming.
5. Example: **01 - 4321 - # - ****

User Code Programming

1. First **INPUT (Owner's Master Code) - ****
2. Set a user pin to operate the ARHO "Door Open". **INPUT 10 - 2 - 001 - (User Code) - 1 - #** Keep in mind that the "001" is the unique User ID for the code you're inputting. *(Note: The User ID must be unique for every 4-digit code and can range from 001 to 100).*
3. Set a user pin to operate the ARHO "Door Close". **INPUT 20 - 2 - 001 - (User Code) - 3 - #**
4. Press ****** to exit programming, you will hear two beeps to confirm.
5. Example: [For User ID #1 Door Open **INPUT 10 - 2 - 001 - (User Code) - 1 - #**] [For User ID #1 Door Close **INPUT 20 - 2 - 001 - (User Code) - 3 - # - ****]

EXTERIOR KEYPAD OPERATION

1. To open the door **INPUT (Your User Code) - 1 - #**
2. To close the door **INPUT (Your User Code) - 3 - #**

TROUBLESHOOTING

The hatch will only move UP or DOWN not both ways.

Upon first operation the hatch may only move one way. Continue moving the hatch that way to complete the cycle. Once the actuator completes the cycle, you will be able to operate the hatch in the opposite direction.

The hatch doesn't move at all.

If you get no movement at all, first check all your electrical connections. Make sure the plugs are securely snapped in correctly, and make sure the actuator and data cables are inserted into the correct ports.

The hatch only works with the remote or Keypad.

If the hatch will operate with the Keypad only, the remote might need to be synchronized with the receiver. To do this see step 22. If the hatch only operates with the remote, check the connections on the Keypad and the signal box. If the Keypad has power, and you see the red light when you enter the User Code, you may need to open it up and check if there are any loose wires.

MAINTENANCE

Your SafePro automatic hatch opener requires very little maintenance. Follow the schedule below to ensure trouble-free operation of your system.

MONTHLY -

- Perform a physical inspection of the entire system.
- Make certain all parts are moving freely.
- Ensure the latch tongue releases properly and does not restrain the opening of the hatch.
- Inspect for any loose wires that may have been snagged while operating the lid or got snagged entering or exiting the system.

SEMI-ANNUALLY (twice a year) -

- If equipped, check the charging status of your battery by pressing the STATUS INDICATOR button on the front of the battery.
- If you notice it's charging to only 75% or less, the battery is not operating at maximum capacity, and needs replacement soon. A replacement battery is available for purchase.
- Lightly lubricate the rocker bracket and latch tongue, with a spray lithium grease or silicone-based lubricant, to ensure smooth opening/closing of the lid.
- Ensure the turnbuckle locknut is secure against the black hex-shaft. Because, if the nut gets loose, the turnbuckle can fall out of adjustment, possibly resulting in the latch tongue not releasing. This can result in the lid binding, resulting in damage to the system or the lid.