

USER INSTRUCTION MANUAL METALLIC ANCHORS

THESE INSTRUCTIONS APPLY TO THE FOLLOWING MODELS:

UFA30001, UFA30020, UFA30050, UFA30110, UFA30115, UFA30070, UFA30080, UFA30130, UFA30301, UFA30401, UFA30010, UFA30010N, UFA30015, UFA30015N, UFA55370, UFA55207(12), UFA55207(18), UFA55207E(12), UFA55207E(18), UFA55207SW(12), UFA55207SW(18), UFA30420, UFA30430, UFA30430(SW), UFA30005, UFA30501, UFA30501(04), UFA30021, UFA30021(C), UFA30021(CW), UFA30311, UFA30311(W), UFA30302, UFA30021(AW) and UFA30030



This manufacturer's user instruction manual meets the requirements of ANSI Z359.18-2017. As per OSHA, this manual should be used as a part of an employee training program.

▲ WARNING

The products enumerated in this instruction manual are a part of a personal protective, work support or rescue system. It is important that the user reads and follows the manufacturer's instructions for each component of the system. This manual contains information which is important to the user's safety and should be kept in a safe place for future reference as needed. Please contact KStrong for any questions regarding use of this equipment.

Fall arrest systems and equipment are life saving products and are designed to reduce the potential of serious injury in the event of a fall. However, it is important to note that the user may experience an impact of force on their body in the event of a fall. In case there is a doubt about the user's ability to utilize this product, the user must consult a physician. Pregnant women and minors are not considered fit for the use of this equipment.

TRAINING

In order to ensure that the user is familiar with the instructions provided in this manual, it becomes the responsibility of the employer and user to undergo training in proper inspection, use and maintenance of this equipment.

TECHNICAL SPECIFICATIONS

Model No.	Product Name	Minimum Breaking System	Material of Construction	Complying Norm
UFA30001	Hinged Steel Roof Anchor (Resusable)	5000 lbs.	High Strength Alloy Steel	ANSI Z359.18-2017 Type A
UFA30020	Permanent Use Stainless Steel Roof Anchor		Base Plate: Stainless Steel D-Ring: Medium carbon Steel	ANSI Z359.1-2007
UFA30050	Single Point Anchor		High Strength Alloy Steel	ANSI Z359.18-2017 Type A
UFA30110	Beam Anchor		Aluminium Alloy & Brass	
UFA30115	Beam Anchor		Aluminium Alloy & Brass	
UFA30070	Parapet Anchor with Extended Movable Arm		Galvanized Steel	
UFA30080	Girder Anchor		Stainless Steel with Galvanized Steel Anchorage Eye	
UFA30130	Beam Anchor Trolley		Aluminium Alloy & Stainless Steel	
UFA30301	D-Ring Two Hole Anchor		High Strength Alloy Steel	
UFA30401	Door Anchor		Aluminum Alloy	
UFA30010 UFA30010N	Steel Anchor		Galvanized Steel	
UFA30015 UFA30015N	Steel Anchor		Galvanized Steel	
UFA55370	Aluminium Anchor for Standing Seam Roof		Aluminium Alloy & Stainless Steel	
UFA55207(12) UFA55207(18)	Steel Anchor		Galvanized Steel	
UFA55207E(12) UFA55207E(18)	Steel Anchor with eye nut		Galvanized Steel	
UFA55207SW(12) UFA55207SW(18)	Steel Anchor with Swivel Eye		Galvanized Steel	
UFA30420	Edge Fix Anchor		Galvanized Steel	
UFA30430 UFA30430(SW)	Anchor for Container Anchor for Container with swivel anchorage eye		Galvanized Steel	
UFA30005	Steel Anchor		High Strength Alloy Steel.	

UFA30021	Permanent use Stainless Steel Roof Anchor	5000 lbs	Stainless Steel with one side stamped D-ring	ANSI Z359.18-2017 Type A
UFA30021(AW)	Permanent use Stainless Steel Roof Anchor without nail		Stainless Steel with one side stamped D-ring	
UFA30021(C)	Permanent use Stainless Steel Roof Anchor		Stainless Steel with one side stamped D-ring	
UFA30021(CW)	Permanent use Stainless Steel Roof Anchor without nail		Stainless Steel with one side stamped D-ring	
UFA30501	Anchor		Galvanized Steel	ANSI Z359.1-2007
UFA30501(04)	Anchor		Galvanized Steel	
UFA30311	Swivel Anchor with Nut Bolt		Galvanized Steel	ANSI Z359.18-2017 Type A
UFA30311(W)	Swivel Anchor		Galvanized Steel	
UFA30302	Concrete Anchor Plate With D-ring		Galvanized Steel	
UFA30030	Bull Ring Anchor		High Strength Alloy Steel.	

IMPORTANT INFORMATION

- It is important to inspect the equipment according to the manufacturer's instructions before each use.
- Inspection of equipment should be done on a regular basis by a qualified person and the results should be recorded in the inspection log.
- DO NOT REMOVE product labels which include important warnings and information for the "Authorized Person".
- "Authorized Person" is a person who is exposed to fall hazards during the course of their work. This individual requires formal training in the use of personal fall protection equipment and systems. The term "Authorized Person" may be used interchangeably with "User" and "End-User".
- DO NOT ALTER the equipment in any way.
- Always send the equipment back to the manufacturer, or to the persons or entities authorized in writing by the manufacturer, for any repairs if required.
- Never use any natural material like manila, cotton, etc. as part of the Fall Protection System.
- Fall protection equipment should only be used for the purpose for which it has been designed.
- This equipment should never be used for towing and hoisting or for any other purpose than its intended use.
- A competent person must ensure compatibility of the system to minimize any potential for accidental disengagement.
- Authorized persons or users shall be trained on all warnings and instructions provided in this manual.
- It is important for all authorized persons and users to refer to the applicable ANSI Standards and to the regulations governing occupational safety.
- Take proper precautions to remove any debris, material, obstructions, etc., from the work area which could cause injury, or otherwise interfere with the functioning of the system.
- KStrong Anchors should be used only with the combinations of components, sub-systems or both which may affect or interfere with the safe function of one another. Be certain that connecting devices are compatible and that other elements of the PFAS are safe and compatible before use.
- Always check for obstructions below the work area to make sure that the potential fall path is clear.
- Keep the equipment away from anything that could damage it such as sharp edges, rough or abrasive surfaces, high temperature surfaces, heat and welding sources, moving machinery, electrical hazards, etc.
- It is important to keep in mind environmental hazards when selecting fall protection equipment.
- Do not expose the equipment to chemicals, highly corrosive or caustic environments, or to direct sunlight and UV radiation, which may cause UV degradation.
- Such harmful environments require a more frequent inspection and servicing program of the fall protection equipment to maintain the integrity and safety of the equipment. Contact KStrong if in doubt.
- All the synthetic material of fall protection equipment must be protected from slag, hot sparks, open flames or other heat sources.
- It is recommended that heat resistant materials are used in such applications. It is important to allow adequate fall clearance below the work surface.
- Always have a Rescue Plan ready and at hand when using this equipment.

WARNING !!

- **Immediately discard any product which is exhibiting unusual wear, deformity or deterioration.**
- **Immediately remove from service any equipment that has been subjected to a fall.**

COMPONENT COMPATIBILITY

Component compatibility with KStrong manufactured fall protection equipment is ensured by strictly following the instructions for each type of equipment used. However, if the user utilizes combinations of components or sub systems that are manufactured by others, only a "qualified" or "competent" person (as defined in OSHA) can ensure the compatibility. If substitutions or replacements are made with non-approved components or sub systems, then this may severely affect the compatibility of the equipment, making the complete system unsafe for use.

COMPATIBILITY OF CONNECTORS

To ensure the compatibility of the connectors with their connecting element, it is important to safeguard that the sizes and shapes of the connectors and the connecting elements do not allow their gate mechanisms to open inadvertently, notwithstanding their orientation with each other. All hooks, carabiners, D-rings and other such connectors must be capable of supporting a min. force of 5000 lbs. (23 kN). All connectors must be compatible with all system components like anchorages, etc. Never use equipment which is not compatible as this may cause the connectors to disengage unintentionally. All connectors must be compatible in shape and size. As per ANSI Z359.12 and OSHA, only self-locking snap hooks and carabiners may be used.

CONNECTIONS USING CONNECTORS

Ensure that only self-locking snap hooks and carabiners are used with this equipment. All connections should be compatible in size, shape and strength. The connectors used should be suitable to each application. Ensure that they are fully closed and locked while in use.

NEVER USE INAPPROPRIATE CONNECTIONS

While using KStrong snap hooks and carabiners, they should not be connected as below:

- Two or more connectors should never be attached to a single D-ring.
- Never attach a connector that could result in a load on its gate.
- Connectors should not be connected in a false engagement. It should be visually confirmed that the connector is fully engaged to the anchor point. Avoid conditions that allow for features that protrude from the connectors to catch on the anchor, giving a false sense of being connected.
- Connectors should not be connected to each other.
- Connectors should not be connected directly to the webbing or to the rope lanyard or tie back, unless specifically allowed by the manufacturer.
- Connectors should not be connected to any object which does not allow the connector gate to close or lock. Anchor shapes that allow roll out to occur should never be used for connection. If the anchor, to which the snap hook or carabiner is attached, is under sized or irregular in shape, then this may allow for the gate of the connector to come in contact with the anchor, thereby causing the connector to open up and possibly disengage from the anchor. This is known as roll out of the connector.

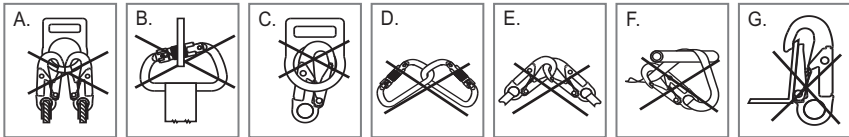

- Do not use connectors on an anchorage object as shown in figure A to G.

▲ WARNING

Large throat opening snap hooks should not be connected to standard size D-rings or similar objects. The reason for this is if the hook or D-ring twists or rotates, then this may result in a load on the gate of the connector. Large throat snap hooks are specifically designed for use on fixed structure elements such as rebar or cross members. These are shaped in such a way that they cannot capture the gate of the hook.

IMPORTANT RESTRICTIONS WHILE MAKING CONNECTIONS

- A snap hook should not be connected into a loop or thimble of a wire rope, or attached to it in any way that may slack the wire rope.
- Do not make connections where the connector locking mechanism can come into contact with a structural member, or other such equipment, as it may potentially unlock the connector and release the connection.
- To connect to a single or a pair of soft loops on a harness, a carabiner that can fully close and lock should only be used. Snap hooks are not allowed for such connections.
- A carabiner may be connected to a loop or ring connector that is already occupied by a choker style connector. Snap hooks are not allowed for such connections.

If the connecting element to which a snap hook (shown) or carabiner attaches is undersized or irregular in shape, a situation could occur where the connecting element applies a force to the gate of the snap hook or carabiner. This force may cause the gate (of either a self-locking or a non-locking snap hook) to open, allowing the snap hook or carabiner to disengage from the connecting point.

Small ring or other non-compatibly shaped element

1. Force is applied to the snap hook.

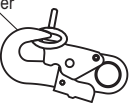

2. The gate presses against the Ring.

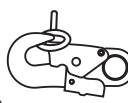

3. The gate opens allowing the snap hook to slip off.



CONNECTING SUBSYSTEMS

Use only those connecting subsystems (self-retracting lifeline, lanyard, rope grab and lifeline, cable sleeves) that are suitable for your application. See subsystems manufacturer's instructions for more information. Some harness models have web loop connecting points. Do not use snap hooks to connect to the web loop. Use a self-locking carabiner to connect to a web loop. Ensure that the carabiner is connected in such a way that it does not lead to cross-gate load. Sometimes lanyards may be sewn directly to the web loop forming a permanent connection. Do not make multiple connections onto one web loop.

RESCUE PLAN

A rescue plan should be well documented and in place before performing work at height. The rescue operation must be performed by trained and competent personnel only. The rescue expert team should supervise the rescue operation performed. It is also advised to work in pairs while working on site.

ENVIRONMENTAL HAZARDS

It is important to take additional precautions while using this equipment in the presence of any environmental hazards so as to prevent injury to the user or damage to the equipment.

Environmental hazards may include the following, but are not limited to:

- Chemicals
- Extreme Temperatures
- Corrosive Environments
- Gases
- High Voltage Power Lines
- Sharp Edges
- Moving Machinery and Vehicles

Please contact KStrong for use of this equipment in the presence of any environmental hazard.

▲ WARNING

This equipment is not designed to be used in high temperature environment. It is important to protect this equipment when using near activities like welding or metal cutting. Hot sparks may cause damage to this equipment or burn it. Contact KStrong with any questions regarding the details on use of this equipment in high temperature environment.

ANCHORAGE STRENGTH

The application type determines the anchorage strength requirement. As per ANSI Z359.1 the necessary anchorage strength for the following applications is listed below:

- **Fall Arrest:** As per OSHA 1926.500 and 1910.66: anchorages that are used for attachment of Personal Fall Arrest Systems (PFAS) shall be independent of any anchorage being used to support or suspend platforms. They should be capable of withstanding a minimum load of 5000 lbs. (23 kN) per user attached, or should be designed, installed and used as part of a complete PFAS which maintains a safety factor of at least two. Rating of the anchorage should always be done under the supervision of a qualified person.
- **Work Positioning:** The structure to which the work positioning system (WPS) is attached must be able to sustain a static load of min. 3000 lbs. (13.3 kN), applied in the directions permitted by the work positioning system. Or, it should be able to sustain two times the potential impact load, whichever is greater; see 1926.502. However, if more than one work positioning system is attached to an anchorage, then the strength mentioned above must be multiplied by the number of WPS attached to the anchorage.
- **Restraint:** The strength requirement of anchorages which are selected for restraint and travel restraint systems is min. of 1000 lbs. (4.5 kN) static load applied in the directions permitted by the system. If more than one restraint and travel restraint system is attached to anchorage, then the 1000 lbs. shall be multiplied by the number of systems attached to the anchorage to determine the min. strength requirement.
- **Rescue:** The minimum strength of the anchorage selected for rescue should be such that it is capable of sustaining a static load of min. 3000 lbs. (13.3 kN) applied in the direction permitted by the system. To determine the strength requirement of the anchorage if more than one rescue system is attached, then multiply 3000 lbs. (13.3 kN) by the number of the systems attached to the anchorage.

GENERAL LIMITATIONS OF FALL ARREST SYSTEM AND REQUIREMENTS

It is important to consider the below mentioned limitations before using or installing this equipment:-

- The **capacity** of the KStrong full body harness is up to 310 lbs. (140 kg) hence, the combined weight (clothes, tools, shoes etc.) of a person using these harnesses should not be more than 310 lbs. It is important to ensure that all the components in the system are rated to a capacity which is appropriate to the application.
- **Free Fall:** As per ANSI Z359.11 the personal fall arrest systems used with this equipment must be rigged in such a way that the free fall does not exceed 6 ft. (1.8 m). Restraint systems must be rigged in such a way that no vertical free fall is possible. Work positioning systems are required to be rigged in a way that the free fall does not exceed 2 ft. (0.6 m). Personal riding systems must be rigged so that there is no vertical free fall possible.

Climbing systems must be rigged so that free fall is less than 18 inches (46 cm). Rescue systems must be rigged in such a way that there is no vertical free fall. Contact KStrong for any further information needed.

- **Fall Clearance:** There should be sufficient clearance below the user to allow the system to arrest a fall so as to prevent the user from striking the ground or any other obstruction. The clearance required depends upon the following factors:

- Harness Stretch - $H_s = H_f - H_1$ (Harness stretch should be \leq (less than equal to) 18 inches)
- Anchorage location
- Type of connecting subsystem used (energy absorbing lanyard, self retracting lifeline (SRL), etc.)

If the only available anchorage is situated below the attachment on the harness; and if there is a risk of fall, then it is essential to use a lanyard with a properly rated energy absorber. It is important to ensure that there is sufficient fall clearance below the user, before using a shock absorbing lanyard. If the weight of the wearer is 220 lbs. and the fall factor is two, we can calculate the fall clearance (which will be equal to the stopping distance H ($2L + 5.74$ ft.) + an additional distance of 3.28 ft).

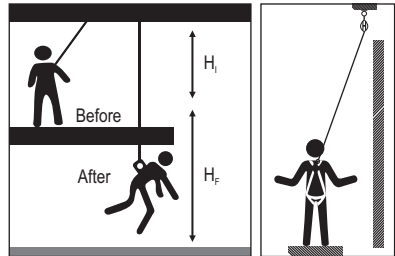
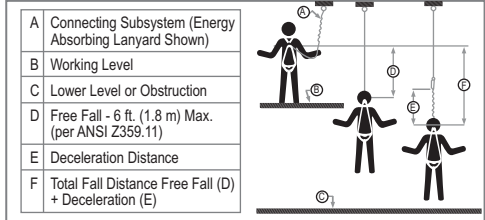

Calculating Total Fall Distances:

Total Fall Clearance below worker is calculated from Anchorage Connection. Free Fall Distance + Energy Absorber Deceleration Distance + Worker height + Safety Factor. Care must be taken to ensure that the total fall distance is clear of obstructions; such as equipment, to avoid contact with a lower level.

Free Fall Distance + Energy Absorber Deceleration Distance + Worker height + Safety Factor = 19 ft. (5.8 m)

Free Fall Distance + Energy Absorber Deceleration Distance + Worker height + Safety Factor = 20 ft. (6.1 m)

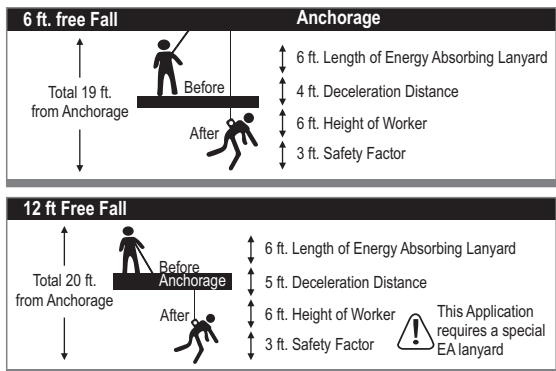

- **Swing Falls:** Swing fall occurs when the position of the anchorage point is not directly above the point where a fall occurs. In such a case if a fall were to occur, it will result in pendulum swing of the fall victim and may also cause them to strike nearby objects with a force. This may cause serious injury or even death. Such swing falls may be minimized by ensuring that the anchorage is directly overhead, and by working as close to the anchorage point as possible. Swing falls will substantially increase the fall clearance required when a SRL or other variable length connecting subsystem is used.
- **Extended Suspension:** Using a full body harness: AFBH is not intended for use in extended suspension applications. If the user is going to be suspended for an extended length of time, it is recommended that some form of a seat support be used. KStrong recommends a seat board, suspension work seat, seat sling, or a boatswain chair. Contact KStrong for more information on these items.

Periodic Examination: Always keep the instructions provided with the product. Take the information from the markings on the product and enter this information in the identification sheet. To ensure the safety of the user, it is essential to check the condition of the equipment through periodic examinations of the product. This equipment must be examined by a qualified person at least once in a six months, strictly complying with the manufacturer’s instructions. Also, record the previous check on the attached sheet. If the equipment is in heavy usage or is used in a harsh environment, then the frequency of inspection should be increased in accordance with regulations. Also check that the markings on the product are legible.

SPECIFIC INSTRUCTIONS

Kstrong Anchors are designed to provide complete attachment system to the user in the event of a fall. These attachment systems must be connected to proper body support and connecting facility. These Anchors are meant to hold the victim of fall till the rescue operation is performed, so this is important that the whole system must have all the essential components before going for use. The whole fall arrest system must be used by a trained/competent person. It is advisable to make a checklist of the essential components according to one’s use before going for work.

USE OF FALLARREST SYSTEM

The fall arrest system **MUST ONLY** be connected to the back attachment element on the harness provided for the purpose (“D” ring or webbing attachment extension) or to the chest anchorage points (“webbing link” or “D” link). The chest anchorage points must imperatively be used together. The D-rings on the belt and the ventral anchorage point must only be used for the attachment of a work positioning or retaining system and never with a fall arrest system.

During use, check regularly the adjustment and/or attachment points.

INSPECTION

Before each use, proceed with thorough visual examination to ensure that the PPE is intact (the same applies for the equipment used with the harness (connectors, lanyard...)) and take all necessary steps concerning the implementation of rescue in total safety. In the event of your product being contaminated, consult the manufacturer or authorized agent. If you have any doubts regarding the safe state of the product or if the product has been used to arrest a fall, for your personal safety, it is essential to withdraw the PPE from service and send it back to the manufacturer or a qualified repair Center for checking or destruction.

Before each use of this equipment inspect it according to the following guidelines: A formal inspection of fall protection products/components must be performed at least every six months by a competent person other than the user. The frequency of formal inspections should be based on conditions of use or exposure. Record the inspection results in the inspection and maintenance log at the end of this manual. The component should be checked for Cut, Frayed, Heavily Soiled, Welding Burns etc. Metal parts like D-rings should be duly checked for cracks, bents, deformities, corrosions etc.

Following the inspection, the center will provide written authorization or refusal for the use of the PPE. Never attempt to modify or repair PPE.

Instructions for Installation of Hinged Steel Roof Anchor (Reusable) (UFA30001)	
<p>This Steel Anchor is designed to be used as a temporarily installed anchorage connector on wooden frame structures.</p> <p>STEP 1: Spread the anchor base legs apart such that it is aligned with the surface on to which it is to be mounted on, that is either a roof peak or a flat surface.</p> <p>STEP 2: Position the anchor on the roof such that the nailing holes along with the center of the legs are over a framing member.</p> <p>STEP 3: Push down the anchor to butt the legs over the surface and insert the supplied nails.</p> <p>The Anchor can be fixed so that the load impact is in the direction shown in the adjacent figure :-</p>	<p>16d X 3.5" long Nails (Qty-22 Nos)</p> <p>UFA30001</p>

- When installed as an anchor point on a flat surface or on one side of a peaked roof, the connecting fall arrest subsystem must not extend over the peak of the roof to the other side.
- When working on the opposing roof surface, installation of an additional Hinged Reusable Steel Roof Anchor is required on that side.
- Anchor must be positioned to apply load in the long axis of the anchor bracket. After removal of the Hinged Reusable Steel Roof Anchor, roof surface may require repairs. It is the responsibility of the installer to make applicable repairs to the roof materials.
- The Hinged Reusable Steel Roof Anchor can be used on a maximum roof slope of 12/12 pitch.

Attachment : Center on the ridge of roof framing assembly. Position the anchor on the roof such that the holes along the center of the legs are centered directly over the center of the roof framing member. The roof anchor must be positioned over top of previously secured roof sheathing (do not attach directly to rafter or truss).

Nails: The 6 center holes and 1 row of the outer holes on each leg must be used. The 6 center holes must be centered on the framing section and the 5 outer holes must penetrate through substrate. Total of 22 nails must be used. Minimum ply wood thickness = 1/2" nominal. Nail size to be used 16d 3.5" long.

Screws: The 6 center holes on each leg must be used. 3" long # 12 stainless screws must be installed in the center of the framing section. Minimum Ply wood thickness 1/2".

Instructions for Installation of Permanent use Stainless Steel Roof Anchor (UFA30020, UFA30021)

This Roof Flange anchor is specially designed to be used on wooden frame structures as a permanent anchor. This anchor is to be used as part of a personal fall arrest system or a restraint system. Do not use this anchor as a termination anchor for horizontal lifeline. The following guidelines may be followed for locating the roof anchors:

- The roof anchor should be installed as close to the roof peak as possible, at least 6 feet away from any exposed edge.
- It should be attached only on supported wooden structure.
- The minimum spacing between any two roof anchors should be 8 feet.



Fig. 1- Wooden roof structure onto which anchor is to be installed.

Fig. 2- Position the anchor on the roof and alternately insert the nails.

Fig. 3- Now the D-ring can be used as anchorage point.

STEP 1: Place the anchor plate to match the surface it will be mounted on, either a roof peak or flat surface. Ref fig. 1. The anchor must be placed in such a way that the product label faces upward and butyl flash tape sticks to the roof surface.

Note: The Butyl flash tape provides tolerable weather protection and water proofing, hence allowing the steel roof anchor to be installed directly on the roof surface without removing ridge cap / roof.

STEP 2: Press down the anchor legs over the surface and alternately insert the provided nails. Ref. fig. 2. Insert fasteners in all the pre-formed holes on the anchor plate as per the table given below.

Table: Substrate And Fasteners Specifications for UFA30020

	Underlying structure	Minimum Thickness of substrate	Nails/ screws specs	Total No	Min on each side
1	Wood (supported by truss)	3.5 inches	Screws: #12; 2 inch length	8	4
	Wood (not supported by truss)	3.5 inches	Nails: 16d; 3 inch length	8	4
2	Metal	20 gauge	Metal deck screw	8	4

Table: Substrate And Fasteners Specifications for UFA30021, UFA30021(AW), UFA30021(C), UFA30021(CW)

	Underlying structure	Minimum Thickness of substrate	Nails/ screws specs	Total Nos.
1	Wood	3.5 inches	Screws: #12; 2 inch length/ Nails: 16d ; 3.5"	10 nos. for UFA30021, UFA30021(AW) 06 nos. for UFA30021(C), UFA30021(CW)
2	Metal	20 gauge	Metal deck screw	10 nos. for UFA30021, UFA30021(AW) 06 nos. for UFA30021(C), UFA30021(CW)

Instructions for Installation of Steel Point Anchor (UFA30050)

This Single Point Anchor is to be used for anchorage in a fall arrest system. It can be fixed to walls, ceilings, roof tops or steel structures present in the working environment.

- **For fixing on steel structures:** Drill a hole of dia 1/2 inches in the steel structure (pass through) and bolt the anchor on to it by using one M 12 steel nut bolts. Ensure that the nut and bolt are tightened strongly.
- **For fixing to walls, ceiling and roof tops:** Fix only on the ones made up of concrete and known to have compression strength of at least 3000 PSI. Use one M12 chemical fastener to fix the anchor into the hole drilled in the concrete structure as per the instructions provided by the fastener's manufacturer.

The Anchor can be fixed so that the load impact is in any of the directions shown in the adjacent figure :-

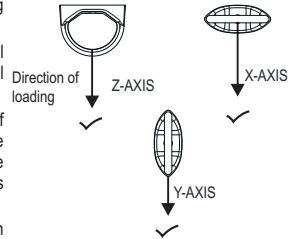

Instructions for Installation of Parapet Anchor with Extended Movable Arm (UFA30070)

Parapet Anchor with Extended Movable Arm that is intended to be installed on a parapet wall up to 14.1 inches (360mm) thickness.

- STEP 1:** Unscrew the set screws so that the points do not protrude into the anchor slot. Remove the detent pin and move the adjustable arm back far enough to allow the clamp to fit over the parapet wall.
- STEP 2:** Make sure the top surface within the anchor slot is fully seated on the parapet wall.
- STEP 3:** Slide the adjustable arm towards the parapet wall and reinsert the locking pin through the appropriate position setting holes.
- STEP 4:** Tighten each set screw until it makes contact with the parapet wall. Tighten the screws with hands until snug. Excessive torque can damage the parapet wall or the parapet wall anchor.

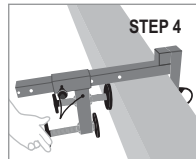
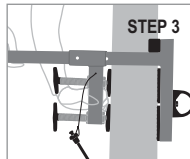
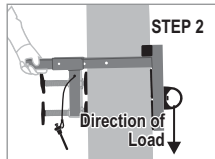
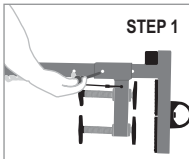
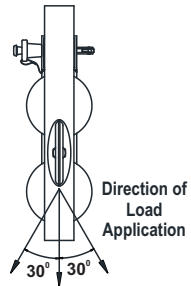

Instructions for Installation of Beam Anchor Trolley (UFA30130)

Beam Anchor Trolley is intended to be installed on flanges of beam from 3.15" to 9.84" width.

STEP 1: Push the latch and adjust the movable jaw enough to allow the clamping jaws to fit over the flange of beam and release the latch to lock its position.

STEP 2: Use the D-ring as connecting point.

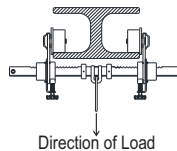

Instructions for Installation of Beam Anchor (UFA30110)

Beam anchor is intended to be installed on flanges of beam from 3.54" to 13.38" width.

- Push the latch and adjust the movable jaw enough to allow the clamping jaws to fit over the flange of beam and release the latch to lock its position.
- Use the D-ring as connecting point.

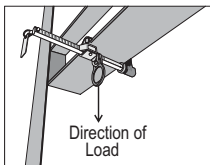

Instructions for Installation of Beam Anchor (UFA30115)

Beam anchor is intended to be installed on flanges of beam from 2.95" to 5.90" width.

- Push the latch and adjust the movable jaw enough to allow the clamping jaws to fit over the flange of beam and release the latch to lock its position.
- Use the D-ring as connecting point.

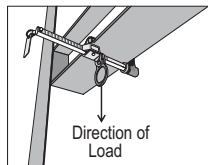

Instructions for Installation of D-Ring Two Hole Anchor (UFA30301)

INSTRUCTIONS FOR USAGE :

- STEP 1:** Install D-ring 2 Anchor with bolts, or weld to substrate.
- STEP 2:** For Metal installations, bolts must be fully embedded in substrate, and must be compressed flush against D-ring 2 Anchor.
- STEP 3:** For concrete installation, drill (2) 3½" holes at bolt installation locations; ½" play will be left at bottom of bolt hole. Then, install D-ring 2 Anchor with bolts.
- STEP 4:** install D-ring 2 Hole Anchor so intended loads will always be applied in a proper and compatible manner; ALWAYS adhere to proper/improper loading requirements as shown.
- STEP 5:** Attach complete and compatible PFAS to D-Ring 2 Anchor.

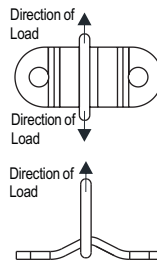

Instructions for Installation of Door Anchor (UFA30401)

Door anchor is intended to be compressed against the Door or Window frame jamming itself between the two vertical sides.

- STEP 1:** Remove the locking pin and adjust the opening of the door anchor arms, so that the jamming frames can take their places, now insert the locking pin into nearest hole of the door anchor body.
- STEP 2:** Set the locking lever into open position and tighten the cup washer for proper grip. Lock the threaded bar by moving the locking lever into closed position. Both Anchorage eyes can be used as the anchorage points.

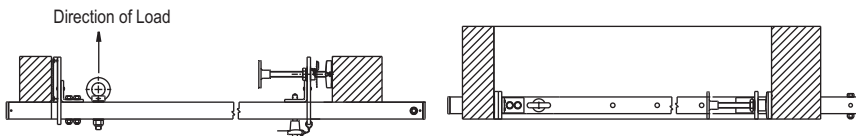

Instructions for Installation of Steel Anchor (UFA30010, UFA30010N, UFA30015, UFA30015N)

This Steel Anchor is designed to be used as a temporarily installed anchorage connector on wood frame structures-

- Spread the anchor base legs apart to match the surface it will be mounted on, either a roof peak or flat surface.
- Position the anchor on the roof such that the nailing holes along with the center of the legs are over a framing member.
- Push down the anchor to butt the legs over the surface and insert the supplied nails.

The Anchor can be fixed so that the load impact is in the directions shown in the figure below :-

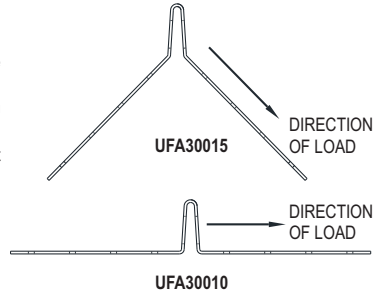

Instructions for Installation of Aluminium Anchor For Standing Seam Roof (UFA55370)

- Install the Anchor on the standing seam roof with help of supplied set screws.
- Connect the lifeline to the anchorage eye of the product.
- Now, product is ready for use.

**Compatible for Standing Seam Roof Steel Sheets
With Minimum Sheet Thickness of .05mm**

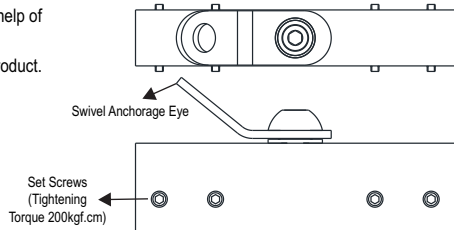

Instructions for Installation of Anchor - UFA55207(12), UFA55207(18)

- Anchor Post can be installed on different structures like concrete, I- beam & other metal structures by use of their suitable fasteners & other attachments. The post are available in sizes of 12" & 18" and can be selected depending on the position.
- Anchor post can be used on concrete by using chemical fastener.
- Fix the plate onto all 4 chemical fastener studs & tighten the nuts on the top of the post plate.
- Threaded top can be used to fix suitable Eye Bolt/ Swivel attachment to create the anchor point.
- Now it can be used as an Anchor post.
- For fixing on metal Structure or I-beam, Specialized Fisher plates & fasteners to be used.
- Can accommodate pitch distance from 150.0mm to 220.0mm .
- M12 Chemical Fastener ; Make : Hilti is to be used.
- On metal structure SA-25(01)SUB1 fisher plate and fastener is to be used.

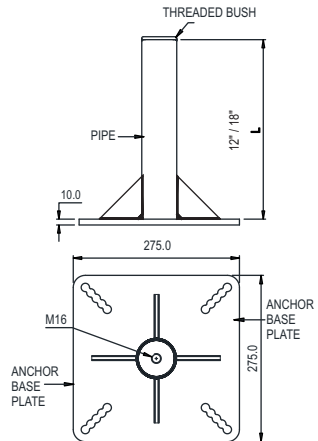

Instructions for Installation of Anchor with eye nut - UFA55207E(12), UFA55207E(18)

- Anchor Post can be installed on different structures like concrete, I-beam & other metal structures by use of their suitable fasteners & other attachments. The post are available in sizes of 12" & 18" and can be selected depending on the position.
- Anchor post can be used on concrete by using chemical fastener.
- Fix the plate onto all 4 chemical fastener studs & tighten the nuts on the top of the post plate.
- Eye nut on top can be used as an anchor point.
- For fixing on metal Structure or I-beam, Specialized Fisher plates & fasteners to be used.
- Can accommodate pitch distance from 150.0mm to 220.0mm .
- M12 Chemical Fastener ; Make : Hilti is to be used.
- On metal structure SA-25(01)SUB1 fisher plate and fastener is to be used.

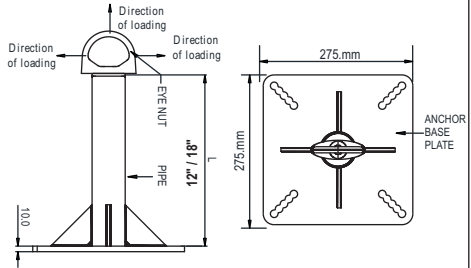

Instructions for Installation of Anchor with Swivel Eye - UFA55207SW(18), UFA55207SW(12)

- Anchor Post can be installed on different structures like concrete, I-beam & other metal structures by use of their suitable fasteners & other attachments. The post are available in sizes of 12" & 18" and can be selected depending on the position.
- Anchor post can be used on concrete by using chemical fastener.
- Fix the plate onto all 4 chemical fastener studs & tighten the nuts on the top of the post plate.
- Swivel D-ring assembly on top can be used as an anchor point.
- For fixing on metal structure or I-beam, specialized fisher plates & fasteners to be used.
- Can accommodate pitch distance from 150.0mm to 220.0mm.
- M12 Chemical Fastener ; Make : Hilti is to be used.
- On metal structure SA-25(01)SUB1 fisher plate and fastener is to be used

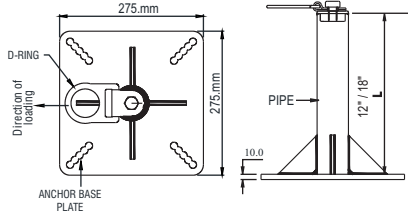

Instructions for Installation of Anchor for Container (UFA30430, UFA30430(SW))

INSTALLATIONS FOR USAGE:

- Pull the side lock up with help of tag line for ease of installation.
- Insert the bottom plate of the anchor in the pre-defined profile on container.
- After inserting, rotate the anchor to lock the structure.
- Release the side lock down, it will prevent the anchor from coming out of the structure accidentally.
- Now holes on the anchor plate in UFA30430 may be used as anchorage point.

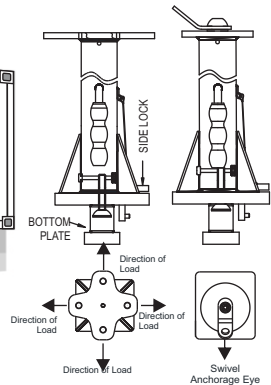
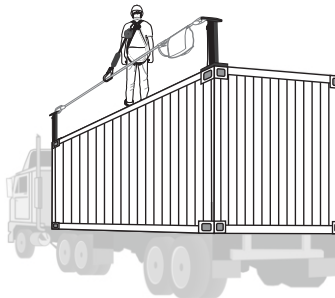

UFA30430(SW) COMES WITH SWIVEL ANCHORAGE EYE

Instructions for Installation of Steel Roof Anchor (UFA30005)

INSTRUCTIONS FOR USAGE:

- Place Anchor at selected installation location.
- Minimum substrate thickness required as follows:
 - Wood (in field): 3/4" CDX or better
 - Wood (truss): 3.5" combined thickness or better
 - Metal: 20g or better
- For Wood substrates, install all (6) provided 1/4" x 3" lag screws OR (12) provided 3" 16d nails in fastener installation holes.
- For Metal substrates of 20g or better, install (6) 1/4" x 3" metal deck screws (not provided).
- Screws must be installed in bottom, middle, and top fastener installation holes on each side of Anchor.

- Nails must be installed in all available fastener installation holes. Fasteners must be fully embedded in substrate.
 - NEVER use Anchor in permanent installations. Anchor may be removed and reinstalled in multiple installation locations.
 - ALWAYS inspect the Anchor prior to each installation. ALWAYS use new fasteners for each new installation.
 - Attach complete and compatible PFAS to Anchor O-ring. NEVER make attachments to any other part of Anchor.
- * This Anchor may be used in combination with a Horizontal Lifeline (HLL). All set-up, installation, and use of HLLs must be done under the supervision of a Qualified Person.**

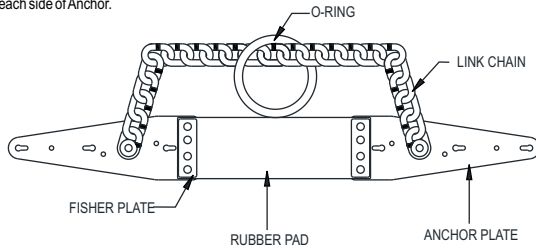

Instructions for Installation of Edge Fix Anchor (UFA30420)

Installation steps :-

- Place the anchor onto the I beam while the clamps are loosened.
- Slide in the clamps so as to fit the size of I beam
- Tighten the clamps to the fullest with help of Studs & Nut.
- Tighten center bolt to ensure anchor is in desired upright position.
- Now, holes on the plates can be used as anchor point for installation of lifeline or to be used as individual anchorage point.

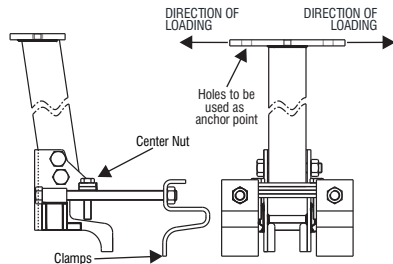

Instructions for Installation of Drop Thru Anchor with Swivel D-ring (UFA30501, UFA30501(04))

- The Anchor device is used to make the Anchor point on concrete, steel decking or steel grating. Anchor point can be used to make a personal fall protection, restraint system, rescue or work positioning.
- Anchor can be installed either at time of pouring of concrete or by making a drill on concrete. Make a drill of 1-3/4" through the concrete & clean the hole by air pressure & insert the Anchor from top side of concrete structure.
- Now Anchor is ready to use.
- Thickness of concrete & distance from edge should be duly checked & approved by a qualified structural engineer.

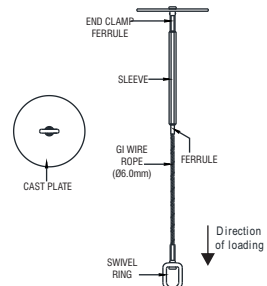

Instructions for Installation of Swivel Anchor Post (UFA30311, UFA30311(W))

The Swivel Anchor Post is designed to function as an interface between the anchorage and fall protection, work positioning, rope access, or rescue system. This serves the purpose of coupling the system to the anchorage. Any references to "anchorage connector" in this manual include, and apply to, the Swivel Anchor Post.

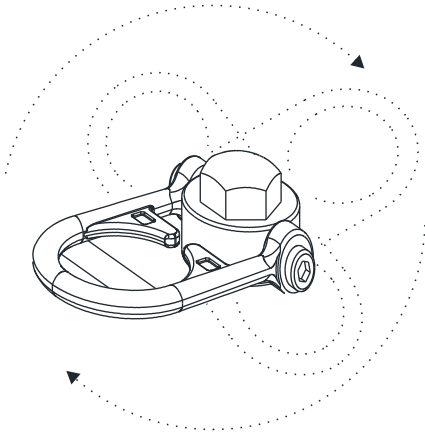

Working load: 1000 lbs (453 kgs)
 Can be used with Horizontal Life Line Systems
 Weight: 1.2-lbs (544.31g)
 Materials: Zinc plated steel

UFA30311(W)

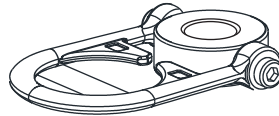

UFA30311

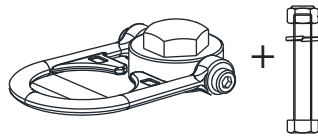

To be installed on metal structure & Comes with 5/8" – 4" long hex head bolt along with washer & nut

UFA30311

- A bolt no shorter than 4' (100mm) with a grade 5-8 (or equivalent) with a locking nut and washer must be used for all steel applications. A swivel anchor must be flushed with steel surface. For all metric applications a 16mm bolt may be used in place of 5/8"-16.

Torque Range: 75-90 ft-lbs (100-120Nm)

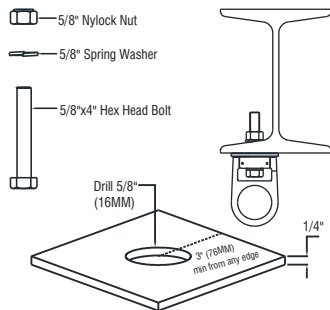

UFA30311(W)

- Use a proper drill & bit for concrete. (SDS drill bit)
- Drill a 3/4" (19mm) hole no less than 5" (127mm) deep 9" (229mm) away from any edge.
- Hole must be straight & perpendicular to surface.
- Hole must be free of debris
- Use Mechanical Fastener Sleeve anchor Make HILTI HLC-H 16x140/90 #385855 to install UFA30311(W).
- Concrete strength must be at least 3000psi (20.7MPa) and no less than 7" (178mm) thick.

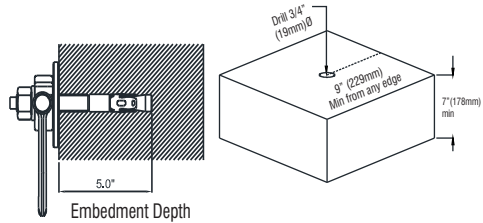

Torque Range: 3-5 full turns beyond hand tight

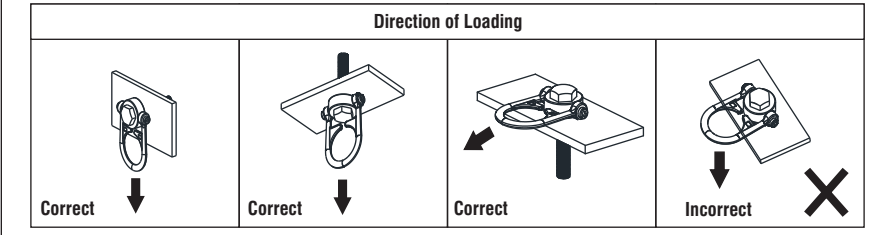

Instructions for Installation of Concrete Anchor Plate With D-RING (UFA30302)

ANCHOR LOCATION: Anchor plates should only be located at points that are structurally sound and in accordance with the given system requirements. All anchoring holes should be at a minimum of 4 inches from the free edges. In case of two or more concrete anchors mounted on one anchorage, a separation gap of a minimum of 10 inches should exist.

Note: The use of plates as guide is a must; it shall prevent the drills from wandering, while drilling holes and installing bolts.

INSTALLING THE ANCHOR: Anchor Installation will require drilling holes in the concrete surface and insertion and affixation of accompanying anchor bolts.

STEP-1 Take a 0.5 inch long carbide drill bit and drill four holes, each 3.75 inches deep. Use compressed air or a blow-out bulb to clean the holes post drilling.

STEP-2 Take the washer and nut and assemble it into the bolt. Now, hold the nut and screw it into the bolt until it is completely flush with the top part, which protects the threads. Insert the bolt into the holes on the anchor plate until the washer is pressed between the nut and the plate.

STEP-3 Tighten the bolt with a torque of 55 ft. lbs for installation and let it expand. The minimum immersion in concrete should be of at least 2.25 inches.

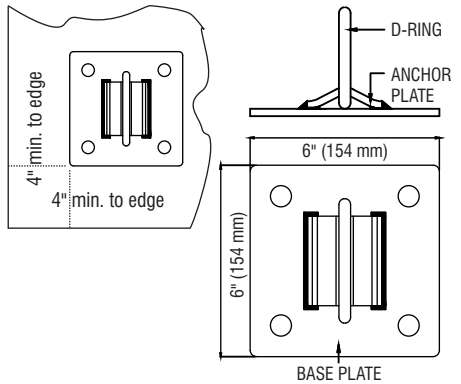

Instructions for Installation of Bull Ring Anchor - UFA30030

- Worker weight capacity range for all applications, including clothing, tools, and equipment, is 130-420 lbs.
- The substrate must be a minimum of 1/2" CDX plywood or better, and the support beam should consist of 2 1/2" (3" in total) material.
- You can use either (6) 16d, 3" long, 8-gauge nails or (3) 1/4" x 3" zinc-plated steel hex head lag screws as fasteners. Ensure that all fasteners are fully embedded into the substrate for secure installation.
- These fasteners are suitable for multiple installation applications, and it is important to use new fasteners for each installation. They are also appropriate for use in horizontal lifeline applications, providing safety and stability in various scenarios.

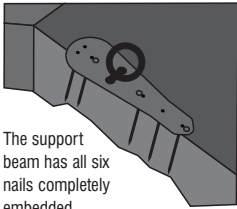

Nail installation

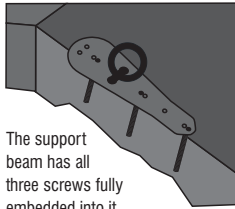

Screw installation

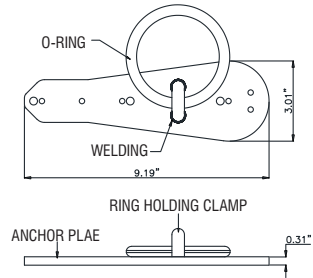

ALWAYS use applicable fastener hole locations as shown (nails/ screws).

ANCHORAGE STRENGTH : The Anchorage strength required depends on the application type. Following are the requirements of ANSI 359.1 for these application types:-

- **Anchorage & anchorage strength :** Anchorage and anchorage strength requirements are dependent on the full body harness application. In accordance with ANSI Z359.1, anchorages selected for fall Arrest Systems must meet the anchorage strength requirements defined in below Table.

Table - Anchorage Strength Requirements

Fall Arrest ¹	Non-Certified Anchorage:	5000 lbs. (23 kN)
	Certified Anchorage ² :	2 Times the Maximum Arresting Force for Certified Anchorage
Restraint ¹	Non-Certified Anchorage	1,000 (4.5 kN)
	Certified Anchorages ² :	2 times the foreseeable force for certified anchorages.
Work Positioning ¹	Non-Certified Anchorages	3,000 lbs (13.3 kN)
	Certified Anchorage ² :	2 times the foreseeable force for certified anchorage.
Rescue ¹	Non-Certified Anchorage	3,000 lbs (13.3 kN)
	Certified Anchorage ² :	5 times the foreseeable force for certified anchorage.
Climbing	The structure which a climbing system is attached must sustain the loads required by that particular system. See the instructions for the climbing system for requirements.	

1 Multiple Systems: When more than one of the defined system is attached to an anchorage, the strength defined for Non-Certified or certified anchorage shall be multiplied by the number of systems attached to the anchorage.

2 Certified Anchorage: An anchorage for fall arrest, positioning, restraint, or rescue systems that a qualified person certifies to be capable of supporting the potential fall force that meet the criteria for a certified anchorage prescribed in this standard.

- **Field Serviceability Testing** - It is not required and also not recommended to perform this testing by the End user.
- **Fall Arrest:** Anchorages selected for fall arrest systems shall have a strength capable of sustaining static loads applied in the directions permitted by the system of at least: 1. 5000 lbs. (23 kN) for non-certified anchorages, or 2. Two times the maximum arresting force for certified anchorages. When more than one fall arrest system is attached to an anchorage, the strengths set forth in (1) and (2) above shall be multiplied by the number of systems attached to the anchorage.
- **As Per OSHA:** Anchorages used for attachment of personal fall arrest systems shall be independent of any anchorage being used to support or suspend platforms and capable of supporting at least 5,000 lbs.(23 kN) per user attached, or be designed, installed and used as part of a complete PFAS which maintains a safety factor of at least two, and is under the supervision of a qualified person.
- **Work Positioning:** The structure to which the work positioning system is attached must sustain static loads applied in the directions permitted by the work positioning system of at least 3,000 lbs., or twice the potential impact load, whichever is greater. See OSHA. When more than one work positioning system is attached to an anchorage, the strengths stated above must be multiplied by the number of work positioning systems attached to the anchorage.
- **Restraint:** Anchorages selected for restraint and travel restraint systems shall have a strength capable of sustaining static loads applied in the directions permitted by the system of at least: 1. 1,000 lbs. (4.5 kN) for non-certified anchorages, or 2. Two times the foreseeable force for certified anchorages. When more than one restraint and travel restraint system is attached to an anchorage, the strengths set forth in (1) and (2) above shall be multiplied by the number of systems attached to the anchorage.
- **Rescue:** Anchorages selected for restraint and travel restraint systems shall have a strength capable of sustaining static loads applied in the directions permitted by the system of at least: 1. 3,000 lbs. (13.3 kN) for non-certified anchorages, or 2. Five times the foreseeable force for certified anchorages. When more than one restraint and travel restraint system is attached to an anchorage, the strengths set forth in (1) and (2) above shall be multiplied by the number of systems attached to the anchorage.
- **Fall clearance :** If there is a risk of fall or if the only anchorage is below the attachment points on the harness, it is essential to use a lanyard provided with an energy absorber. Before using a shock-absorbing lanyard, check that there is sufficient fall clearance below the user to prevent any collision with the structure or the ground.

PERIODIC EXAMINATION:

Keep these instructions with the product and fill in the identification sheet, entering the information taken from the markings.

- The periodic examination is essential to test the resistance and condition of the equipment and to guarantee the safety of the user.
- A qualified person must examine this equipment at least once each year in strict compliance with the instructions of the manufacturer and the previous check must be recorded on the attached sheet.
- The frequency of inspection should be increased in accordance with the regulations, if the equipment is in heavy usage or if the equipment is used in harsh environments. Also Check that the markings are legible.

SYSTEM REQUIREMENTS:

- **Compatibility of Components:** KStrong Fall Protection equipment is designed to be used with KStrong approved components. Please contact KStrong if you have a question regarding compatibility. Making substitutions without approval from KStrong Fall Protection may lead to injuries and or death by compromising the safety and reliability of the complete system. A Qualified person can make a determination on compatibility of equipment from different manufacturers.
- **Compatibility of Connectors:** Connectors (D-rings, hooks, carabiners) must be capable of supporting at least 5000 lbs. (23 kN). Do not use equipment that is not compatible. Non-compatible connectors may unintentionally disengage. Self-locking snap hooks and carabiners are required by CSA, ANSI and OSHA. Connectors must be compatible in size, shape, and strength.
- **Making Connections:** Only use self-locking snap hooks and carabiners with any KStrong Fall Protection equipment. Do not use equipment that is not compatible.

MAINTENANCE, CLEANING & STORAGE:

Repairs to equipment can be made only by a KStrong representative or person or entity authorized by KStrong. Contact KStrong for maintenance and repair. Cleaning after use is important for maintaining the safety and life of the equipment. Cleanse the equipment of all dirt, corrosives, and contaminants. If the equipment cannot simply be wiped clean, use a mild soap and water. Rinse, wipe, and hang to dry in shade.

Store the anchorage connector component in a cool, dry and clean place out of direct sunlight. Avoid areas where heat, moisture, light, oil, and chemicals or their vapors or other degrading elements may be present. Equipment which is damaged or in need of maintenance should not be stored in the same area as usable equipment. Heavily soiled, wet, or otherwise contaminated equipment should be properly maintained (e.g. dried and cleaned) prior to storage.

Prior to using equipment which has been stored for long periods of time, a Formal Inspection should be performed by a competent person. For harnesses with Dielectric buckles, pass-thru buckles or Quick Connect Buckles, store the harness with the buckles connected.

TRAINING:

It is the responsibility of the users to ensure that they read, understand, and follow all instructions and are trained in the care and use of this device. Training should be repeated periodically and any time there is a change of components within the system. Training must be conducted without exposing the trainee to a fall hazard

- As Per OSHA: Anchorages used for attachment of personal fall arrest systems shall be independent of any anchorage being used to support or suspend platforms and capable of supporting at least 5,000 lbs. (23kN) per user attached, or be designed, installed and used as part of a complete PFAS which maintains a safety factor of at least two, and is under the supervision of a qualified person.

MARKINGS:

Model: UFA30001

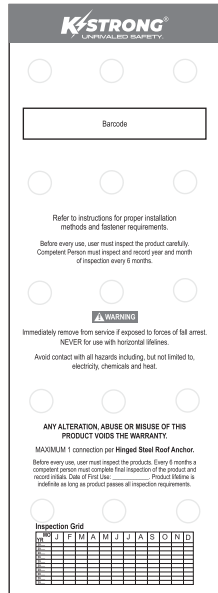
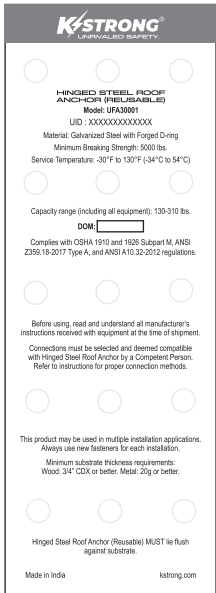

Model: UFA30020

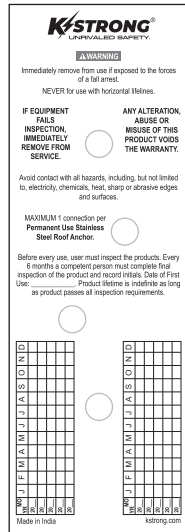
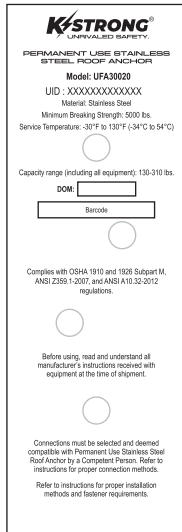

Model: UFA30070



Model: UFA30050

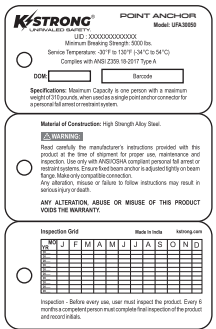

Model: UFA30110

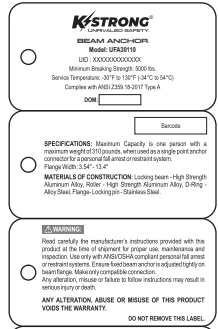

Model: UFA30115

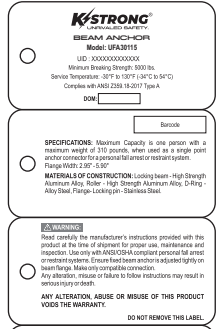



Model: UFA30080



Model: UFA30130

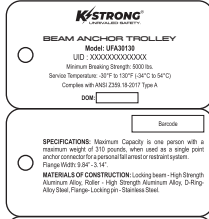

Model: UFA30301

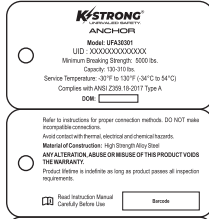

Model: UFA30021



Model: UFA30015

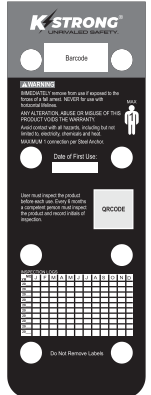

Model: UFA30015N

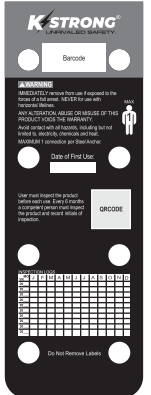

Model: UFA30041



Model: UFA30010

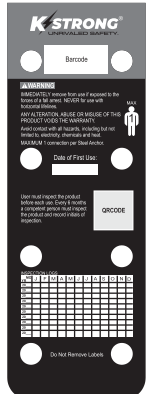

Model: UFA30010N

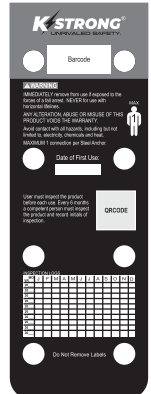
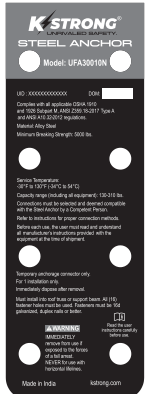

INSPECTION GRID table with date and user information fields

Factory warning text, inspection grid, and QR code information



Model: UFA30005



K-STRONG
UNRIVALED SAFETY.

QR CODE

K-STRONG
UNRIVALED SAFETY.

STEEL ROOF ANCHOR
Model: UFA30005

UID: XXXXXXXXXXXX
Minimum Breaking Strength: 5000 lbs.
Service Temperature: -30°F to 130°F (-34°C to 54°C)
Complies with ANSI Z359.1-2007
Material of Construction: High Strength Alloy Steel.

Specifications: Maximum Capacity is one person with a maximum weight of 310 pounds, when used as an anchor connector for a personal fall arrest or restraint system.

DOM: []

Made in India

WARNING: [] Barcode

Read carefully the manufacturer's instructions provided with this product at the time of shipment for proper use, maintenance and inspection. Use only with ANSI/OSHA compliant personal fall arrest or restraint systems. Ensure fixed beam anchor is subjected to beam flange. Make only compatible connection.
Any alteration, misuse or failure to follow instructions may result in serious injury or death.

ANY ALTERATION, ABUSE OR MISUSE OF THIS PRODUCT VOIDS THE WARRANTY.

Inspection Grid

Yr	M	J	F	M	A	M	J	J	A	S	O	N	D
20													
20													
20													
20													
20													
20													
20													
20													
20													
20													

Made in India

Inspection: Before every use, user must inspect the product. Every 6 months a competent person must complete final inspection of the product and record initials.

Model: UFA55370

K-STRONG
UNRIVALED SAFETY.

ALUMINIUM ANCHOR FOR STANDING SEAM ROOF

UFA55370

UID: XXXXXXXXXXXX
Date of Mfg.: XXXXX
Material: High Strength Aluminium Alloy
Minimum Breaking Strength: 5000 lbs.
Service Temperature: -30°F to 130°F (-34°C to 54°C)
Capacity range (including all equipment): 130-310 lbs.
Complies with all applicable OSHA 1910 and 1926 Subpart M, ANSI Z359.18-2017 Type A and ANSI A10.32-2012 regulations.

Connections must be selected and deemed compatible with Standing Seam Roof Anchor by a Competent Person. Refer to instructions for proper connection methods.

QR CODE

This product may be used in multiple installation applications. Refer to instructions for proper installation methods.

WARNING: Immediately remove from service if exposed to forces of fall arrest.
NEVER for use with horizontal lifelines.
ANY ALTERATION, ABUSE OR MISUSE OF THIS PRODUCT VOIDS THE WARRANTY.
Avoid contact with all hazards including, but not limited to, electricity, chemicals and heat.

MAXIMUM 1 connection per Anchor.

Read the user instructions carefully before use.

Barcode

Before every use, user must inspect the product. Every 6 months a competent person must complete final inspection of the product and record initials.
Product lifetime is indefinite as long as product passes all inspection requirements.

Date of First Use: [] Made in India

Yr	M	J	F	M	A	M	J	J	A	S	O	N	D
20													
20													
20													
20													
20													
20													
20													
20													
20													
20													

DO NOT REMOVE LABELS

UFA30501 / UFA30501(4)

K-STRONG
UNRIVALED SAFETY.

UFA30501 / UFA30501(4)

UID: XXXXXXXXXXXX
Date of Mfg.: XXXXX
Material: Galvanized Steel
Minimum Breaking Strength: 5000 lbs.
Service Temperature: -30°F to 130°F (-34°C to 54°C)
Capacity range (including all equipment): 130-310 lbs.
Complies with OSHA 1910 and 1926 Subpart M, ANSI Z359.18-2017 Type A, and ANSI A10.32-2012 regulations.

Connections must be selected and deemed compatible with anchor by a Competent Person. Refer to instructions for proper connection methods.
Avoid contact with all hazards, including, but not limited to, electricity, chemicals, heat, sharp or abrasive edges and surfaces.

Refer to instructions for proper installation methods and fastener requirements.

WARNING: Immediately remove from use, if exposed to the forces of a fall arrest.
If equipment fails inspection, immediately remove from service.

ANY ALTERATION, ABUSE OR MISUSE OF THIS PRODUCT VOIDS THE WARRANTY.
MAXIMUM 1 connection per Anchor.

Before every use, user must inspect the product. Every 6 months a competent person must complete final inspection of the product and record initials.
Product lifetime is indefinite as long as product passes all inspection requirements.
Do Not Remove Labels

INSPECTION LOG

Yr	M	J	F	M	A	M	J	J	A	S	O	N	D
20													
20													
20													
20													
20													
20													
20													
20													
20													
20													

Date of First Use: [] Made in India

Model: UFA55207(12)

K-STRONG
UNRIVALED SAFETY.

ANCHOR UFA55207(18)

UID: XXXXXXXXXXXX
Date of Mfg.: XXXXX
Material: Galvanized Steel
Minimum Breaking Strength: 5000 lbs.
Service Temperature: -30°F to 130°F (-34°C to 54°C)
Capacity range (including all equipment): 130-310 lbs.
Complies with OSHA 1910 and 1926 Subpart M, ANSI Z359.18-2017 Type A, and ANSI A10.32-2012 regulations.

Before using, read and understand all manufacturer's instructions received with equipment at the time of shipment.
Connections must be selected and deemed compatible with anchor by a Competent Person. Refer to instructions for proper connection methods.
Avoid contact with all hazards, including, but not limited to, electricity, chemicals, heat, sharp or abrasive edges and surfaces.

Refer to instructions for proper installation methods and fastener requirements.

WARNING: Immediately remove from use, if exposed to the forces of a fall arrest.
If equipment fails inspection, immediately remove from service.

ANY ALTERATION, ABUSE OR MISUSE OF THIS PRODUCT VOIDS THE WARRANTY.
MAXIMUM 1 connection per Anchor.

Before every use, user must inspect the product. Every 6 months a competent person must complete final inspection of the product and record initials.
Product lifetime is indefinite as long as product passes all inspection requirements.
Do Not Remove Labels

INSPECTION LOG

Yr	M	J	F	M	A	M	J	J	A	S	O	N	D
20													
20													
20													
20													
20													
20													
20													
20													
20													
20													

Date of First Use: [] Made in India

Model: UFA55207(18)

K-STRONG
UNRIVALED SAFETY.

ANCHOR UFA55207(18)

UID: XXXXXXXXXXXX
Date of Mfg.: XXXXX
Material: Galvanized Steel
Minimum Breaking Strength: 5000 lbs.
Service Temperature: -30°F to 130°F (-34°C to 54°C)
Capacity range (including all equipment): 130-310 lbs.
Complies with OSHA 1910 and 1926 Subpart M, ANSI Z359.18-2017 Type A, and ANSI A10.32-2012 regulations.

Before using, read and understand all manufacturer's instructions received with equipment at the time of shipment.
Connections must be selected and deemed compatible with anchor by a Competent Person. Refer to instructions for proper connection methods.
Avoid contact with all hazards, including, but not limited to, electricity, chemicals, heat, sharp or abrasive edges and surfaces.

Refer to instructions for proper installation methods and fastener requirements.

WARNING: Immediately remove from use, if exposed to the forces of a fall arrest.
If equipment fails inspection, immediately remove from service.

ANY ALTERATION, ABUSE OR MISUSE OF THIS PRODUCT VOIDS THE WARRANTY.
MAXIMUM 1 connection per Anchor.

Before every use, user must inspect the product. Every 6 months a competent person must complete final inspection of the product and record initials.
Product lifetime is indefinite as long as product passes all inspection requirements.
Do Not Remove Labels

INSPECTION LOG

Yr	M	J	F	M	A	M	J	J	A	S	O	N	D
20													
20													
20													
20													
20													
20													
20													
20													
20													
20													

Date of First Use: [] Made in India



Model: UFA30430



Specifications: Capacity: 310 lbs. (140kg) Materials: CED Coated steel UID : XXXXXXXXXXXXX Minimum Breaking Strength: 5000 lbs. Service Temperature: -30°F to 130°F (-34°C to 54°C)

Complies with: ANSI Z359.18-2017 Type A and OSHA requirements

QR CODE

WARNING

Before every use, user must read the instruction manual received with the product at the time of shipment. All instructions regarding proper use, maintenance and inspection must be followed. Any alteration, misuse or failure to follow instructions, may result in serious injury or death.

ANY ALTERATION, ABUSE OR MISUSE OF THIS PRODUCT VOIDS THE WARRANTY.

Inspection:

Inspect the product before each use. Every 6 months, inspection of the product must be done by a Competent Person in accordance with the manual. Do not use if found in defective condition or falls inspection. Should not be repaired by the user.

INSPECTION GRID table with columns YR, MO, J, F, M, A, M, J, J, A, S, O, N, D and rows for 2019, 2020, 2021, 2022.

Date of First Use:

DOM:

Use: Refer to the user instruction manual for details on making connections. Keep the lifeline safe from abrasive surfaces and sharp edges during use. Always use caution when using the equipment near hazardous (thermal, electrical or chemical) sources. Refer to the user manual for additional information.

Made in India kstrong.com

Barcode

Model: UFA30430(SW)



Specifications: Capacity: 310 lbs. (140kg) Materials: CED Coated steel UID : XXXXXXXXXXXXX Minimum Breaking Strength: 5000 lbs. Service Temperature: -30°F to 130°F (-34°C to 54°C)

Complies with: ANSI Z359.18-2017 Type A and OSHA requirements

QR CODE

WARNING

Before every use, user must read the instruction manual received with the product at the time of shipment. All instructions regarding proper use, maintenance and inspection must be followed. Any alteration, misuse or failure to follow instructions, may result in serious injury or death.

ANY ALTERATION, ABUSE OR MISUSE OF THIS PRODUCT VOIDS THE WARRANTY.

Inspection:

Inspect the product before each use. Every 6 months, inspection of the product must be done by a Competent Person in accordance with the manual. Do not use if found in defective condition or falls inspection. Should not be repaired by the user.

INSPECTION GRID table with columns YR, MO, J, F, M, A, M, J, J, A, S, O, N, D and rows for 2019, 2020, 2021, 2022.

Date of First Use:

DOM:

Use: Refer to the user instruction manual for details on making connections. Keep the lifeline safe from abrasive surfaces and sharp edges during use. Always use caution when using the equipment near hazardous (thermal, electrical or chemical) sources. Refer to the user manual for additional information.

Made in India kstrong.com

Barcode

Model: UFA55207E(12)



UID: XXXXXXXXXXXXX Date of Mfg.: XXXXX Material: Galvanized Steel Minimum Breaking Strength: 5000 lbs. Service Temperature: -30°F to 130°F (-34°C to 54°C) Capacity range (including all equipment): ANSI: 130-310 lbs. OSHA: 410 lbs. Complies with OSHA 1910.100, 1926.1004, ANSI Z359.18-2017 TYPE A, and ANSI A10.32-2012 regulations.

Before using, read and understand all manufacturer's instructions received with equipment at the time of shipment. Connections must be selected and deemed compatible with anchor by a Competent Person. Refer to instructions for proper connection methods. Avoid contact with all hazards, including, but not limited to, electricity, chemicals, heat, sharp or abrasive edges and surfaces.

Refer to instructions for proper installation methods and fastener requirements.

Immediately remove from use if exposed to the forces of a fall arrest.

Equipment fails inspection, immediately remove from service.

ANY ALTERATION, ABUSE OR MISUSE OF THIS PRODUCT VOIDS THE WARRANTY.

MAXIMUM connection per Anchor.

Before every use, user must inspect the product. Every 6 months a competent person must complete final inspection of the product and record initials.

Product lifetime is indefinite as long as product passes all inspection requirements.

Do Not Remove Labels

INSPECTION LOG table with columns YR, MO, J, F, M, A, M, J, J, A, S, O, N, D and rows for 2019, 2020, 2021, 2022.

Date of First Use:

Made in India kstrong.com

Model: UFA55207E(18)



UID: XXXXXXXXXXXXX Date of Mfg.: XXXXX Material: Galvanized Steel Minimum Breaking Strength: 5000 lbs. Service Temperature: -30°F to 130°F (-34°C to 54°C) Capacity range (including all equipment): ANSI: 130-310 lbs. OSHA: 410 lbs. Complies with OSHA 1910.100, 1926.1004, ANSI Z359.18-2017 TYPE A, and ANSI A10.32-2012 regulations.

Before using, read and understand all manufacturer's instructions received with equipment at the time of shipment. Connections must be selected and deemed compatible with anchor by a Competent Person. Refer to instructions for proper connection methods. Avoid contact with all hazards, including, but not limited to, electricity, chemicals, heat, sharp or abrasive edges and surfaces.

Refer to instructions for proper installation methods and fastener requirements.

Immediately remove from use if exposed to the forces of a fall arrest.

Equipment fails inspection, immediately remove from service.

ANY ALTERATION, ABUSE OR MISUSE OF THIS PRODUCT VOIDS THE WARRANTY.

MAXIMUM connection per Anchor.

Before every use, user must inspect the product. Every 6 months a competent person must complete final inspection of the product and record initials.

Product lifetime is indefinite as long as product passes all inspection requirements.

Do Not Remove Labels

INSPECTION LOG table with columns YR, MO, J, F, M, A, M, J, J, A, S, O, N, D and rows for 2019, 2020, 2021, 2022.

Date of First Use:

Made in India kstrong.com

Model: UFA30420



UID: XXXXXXXXXXXXX Material: Galvanized Steel Minimum Breaking Strength: 5000 lbs. Service Temperature: -30°F to 130°F (-34°C to 54°C) Capacity: One person use as a single point anchor. Four person use (fixed with 40 ft. and as part of UFA6010 or UFA6010 horizontal lifeline systems).

Complies with ANSI Z359.18-2017 Type A and ANSI A10.32-2012 OSHA requirements

WARNING

Manufacturer's instructions must be read and understood prior to use. Instructions supplied with this product must be followed for proper use, maintenance and inspection. Any alteration, misuse or failure to follow instructions may result in serious injury or death. Make only compatible connections. This equipment must be installed and used under the supervision of a qualified person. Exercise caution using the equipment near hazardous, thermal, electrical or chemical sources. This system may only be used with personal fall arrest systems that maintain fall arrest forces to 5000 lbs. or less. Maximum system capacity is four users per span. Maximum worker weight, including tools and clothing is 310 lbs. Tighten combination clips and trimble nuts to 40 lbs. Remove from service if subjected to fall arrest forces. Do not remove this label.

ANY ALTERATION, ABUSE OR MISUSE OF THIS PRODUCT VOIDS THE WARRANTY.

Inspection - Before every use, user must inspect the product. Every 6 months, a competent person must complete final inspection of the product and record initials.

Date of First Use:

Product lifetime is indefinite as long as equipment passes all inspection requirements.

If equipment fails inspection, IMMEDIATELY REMOVE FROM SERVICE.

DO NOT REMOVE LABELS

INSPECTION GRID table with columns YR, MO, J, F, M, A, M, J, J, A, S, O, N, D and rows for 2019, 2020, 2021, 2022.

Made in India kstrong.com

Model: UFA55207SW(12)



UID: XXXXXXXXXXXXX Date of Mfg.: XXXXX Material: Galvanized Steel Minimum Breaking Strength: 5000 lbs. Service Temperature: -30°F to 130°F (-34°C to 54°C) Capacity range (including all equipment): ANSI: 130-310 lbs. OSHA: 410 lbs. Complies with OSHA 1910.100, 1926.1004, ANSI Z359.18-2017 TYPE A, and ANSI A10.32-2012 regulations.

Before using, read and understand all manufacturer's instructions received with equipment at the time of shipment. Connections must be selected and deemed compatible with anchor by a Competent Person. Refer to instructions for proper connection methods. Avoid contact with all hazards, including, but not limited to, electricity, chemicals, heat, sharp or abrasive edges and surfaces.

Refer to instructions for proper installation methods and fastener requirements.

Immediately remove from use if exposed to the forces of a fall arrest.

Equipment fails inspection, immediately remove from service.

ANY ALTERATION, ABUSE OR MISUSE OF THIS PRODUCT VOIDS THE WARRANTY.

MAXIMUM connection per Anchor.

Before every use, user must inspect the product. Every 6 months a competent person must complete final inspection of the product and record initials.

Product lifetime is indefinite as long as product passes all inspection requirements.

Do Not Remove Labels

INSPECTION LOG table with columns YR, MO, J, F, M, A, M, J, J, A, S, O, N, D and rows for 2019, 2020, 2021, 2022.

Date of First Use:

Made in India kstrong.com

Model: UFA55207SW(18)



UID: XXXXXXXXXXXXX Date of Mfg.: XXXXX Material: Galvanized Steel Minimum Breaking Strength: 5000 lbs. Service Temperature: -30°F to 130°F (-34°C to 54°C) Capacity range (including all equipment): ANSI: 130-310 lbs. OSHA: 410 lbs. Complies with OSHA 1910.100, 1926.1004, ANSI Z359.18-2017 TYPE A, and ANSI A10.32-2012 regulations.

Before using, read and understand all manufacturer's instructions received with equipment at the time of shipment. Connections must be selected and deemed compatible with anchor by a Competent Person. Refer to instructions for proper connection methods. Avoid contact with all hazards, including, but not limited to, electricity, chemicals, heat, sharp or abrasive edges and surfaces.

Refer to instructions for proper installation methods and fastener requirements.

Immediately remove from use if exposed to the forces of a fall arrest.

Equipment fails inspection, immediately remove from service.

ANY ALTERATION, ABUSE OR MISUSE OF THIS PRODUCT VOIDS THE WARRANTY.

MAXIMUM connection per Anchor.

Before every use, user must inspect the product. Every 6 months a competent person must complete final inspection of the product and record initials.

Product lifetime is indefinite as long as product passes all inspection requirements.

Do Not Remove Labels

INSPECTION LOG table with columns YR, MO, J, F, M, A, M, J, J, A, S, O, N, D and rows for 2019, 2020, 2021, 2022.

Date of First Use:

Made in India kstrong.com

Model: UFA55207E(12)



QR CODE

CONCRETE ANCHOR
PLATE WITH DRING
(UFA3030Z)

Material: Galvanized Steel
MBS: 5000 lbs.
Service Temperature:
-30°F to 130°F (-34°C to 54°C)

Capacity range
(including all equipment):
130-310 lbs.

UID: XXXXXXXXXXXXX
Date of Mfg.: XXXXX

Complies with OSHA 1910 and
1926 Subpart M, ANSI Z359.18-2017 TYPE A,
and ANSI A10.32-2012 regulations.

Before using, read and understand all manufacturer's instructions received with equipment at the time of shipment. Refer to instructions for proper connection methods.

WARNING

Avoid contact with all hazards, including, but not limited to, electricity, chemicals, heat, sharp or abrasive edges and surfaces. Immediately remove from use if exposed to the forces of a fall arrest. If equipment fails inspection, immediately remove from service.

Barcode

ANY ALTERATION, ABUSE OR MISUSE OF
THIS PRODUCT VOIDS THE WARRANTY.

Made in India

Before every use, user must inspect the products. Every 6 months a competent person must complete final inspection of the product and record initials.

Product lifetime is indefinite as long as product passes all inspection requirements.

Date of First Use:

INSPECTION LOG

Y	R	M	J	F	M	A	M	J	J	A	S	O	N	D
20														
20														
20														
20														
20														
20														
20														
20														
20														
20														
20														
20														
20														
20														

DO NOT REMOVE LABELS

Model: UFA30311



UFA30311

Read the user manual before use.

Minimum Breaking Working Load - 1000lbs (226kN)

Complies with ANSI Z359.18-2017 Type A

Service Temperature: -30°F to 130°F (-34°C to 54°C)

UID: XXXXXXXXXXXXX
DOM: XXXXXXXX
Made in India

Model: UFA30311(W)



UFA30311(W)

Read the user manual before use.

Minimum Breaking Working Load - 1000lbs (226kN)

Complies with ANSI Z359.18-2017 Type A

Service Temperature: -30°F to 130°F (-34°C to 54°C)

UID: XXXXXXXXXXXXX
DOM: XXXXXXXX
Made in India

Model: UFA30030



Bull Ring Anchor

MAX

Model: UFA30030
Serial No. XXXXXXXX
Batch No. XXXXXXXX
DOM: MMYYYY

Complies with
ANSI Z359.18-2017 Type A



QR CODE



UID: XXXXXXXXXX
Minimum Breaking Strength: 9000 lbs.
Service Temperature: -20°F to 130°F (-29°C to 54°C)
Complies with ANSI Z359.18-2017 Type A
Material of Construction: High Strength Alloy Steel.

Bolt/Bracket Material: Grade 8 or equivalent minimum weight of 3/8 coarse, unless used as a anchor connector for a different material or application.

WARNING

Read carefully the manufacturer's instructions provided with this product in the form of literature for proper use, installation and maintenance. Use only the correct connection method and follow the instructions. Excess load may anchor a failed anchor to the structure. An excessive amount of slack in follow instructions may result in anchor failure or break.

ANY ALTERATION, ABUSE OR MISUSE OF THIS PRODUCT VOIDS THE WARRANTY.

Inspection Date

Y	R	M	J	F	M	A	M	J	J	A	S	O	N	D

Complies with ANSI Z359.18-2017 Type A

NOTE

Do not attempt to disassemble the unit or make repairs to the equipment. Send the equipment back to the manufacturer, or persons or entities authorized in writing by the manufacturer to make repairs to the equipment.

LIFESPAN: The estimated product Lifespan is 10 years from the date of manufacturing. The following factors can reduce the Lifespan of the product: intense use, contact with chemical substances, especially aggressive environments, extreme temperature exposure, UV exposure, abrasions, cuts, violent impacts, bad use or maintenance.

DISCLAIMER: Prior to use, the end user, must read and understand the manufacturer's instructions supplied with this product at the time of shipment and seek training from their employer's trained personnel on the proper usage of the product. Manufacturer is not liable or responsible for any loss, damage or injury caused or incurred by any person on grounds of improper usage or installation of this product.

EQUIPMENT RECORD				
Product:				
Model and type/identification		Trade name		Identification number
Manufacturer		Address		Tel, fax, email
Year of manufacture		Purchase date		Date first put into use
Other relevant information (e.g. Document number)				
PERIODIC EXAMINATION AND REPAIR HISTORY				
Date	Reason for entry (periodic examination or repair)	Defects noted, repair carried out and other relevant information	Name and signature of competent user	Periodic examination next due date



KStrong Inc.
150 N. Radnor Chester Road Suite F200
Radnor, Pennsylvania 19087 United States
Contact number: 1-833-KSTRONG

www.kstrong.com

USA

South America

Asia

UKS/UFA30001/100823/V13